

FortisAlberta Technical Interconnection Requirements for Single-Phase DERs Less than 150kW

DER-01

Revision No: 6.0

2026 / 05 / 28	2026 / 05 / 28			
Prepared	Approved	Owner	Authentication	Validation
Keaton Wheeler Principal Engineer Advanced Power Systems	Michael Simone Manager Operations Engineering	Operational Engineering Services		
Additional Reviewers and/or Contributors	Shane Harbourne, Sr. Lead Engineer P&C Peter Zhou, Sr. Lead Engineer Power Quality Jude Marasigan, Key Accounts Engineer		Authenticated original filed with the Engineering Department	FORTIS ALBERTA

LIMITATION OF LIABILITY AND DISCLAIMER

This document is not a replacement for electrical codes or other applicable standards.

This document is not intended or provided as a design specification or as an instruction manual.

The DER owner, employees or agents recognize that they are, at all times, solely responsible for the generator plant design, construction and operation.

FortisAlberta Inc. (FAI), and any person employed on its behalf, makes no warranties or representations of any kind with respect to the DER requirements contained in this document, including, without limitation, its quality, accuracy, completeness or fitness for any particular purpose, and FAI will not be liable for any loss or damage arising from the use of this document, any conclusions a user derives from the information in this document or any reliance by the user on the information it contains. FAI reserves the right to amend any of the requirements at any time. Any person wishing to make a decision based on the content of this document should consult with FAI prior to making any such decision.

Revision History

Rev	Date	Summary of Changes
6.0	May 2026	<p>UL 1741 CRD for PCS and UL 3141 requirements added for certified PCS-based export-limited and non-export DER configurations, including commissioning and fail-safe verification requirements (4.4, 4.10.8). Default Volt-Watt curve requirement added (4.9.4). Guidance added on using Sandia Group 1 and 2A anti-islanding methods (4.10.3). Added Enter Service Requirements that were pre-existing from IEEE 1547-2018. Relaxed upper applicable voltage for enter service from 1.05 per unit to 1.06 per unit (4.10.5) PCS commissioning requirements added (4.10.8)</p>
5.0	January 2025	<p>Standard changed to single-phase only. IEEE 1547-2018 added as interconnection standard. Alignment to IEEE 1547-2018. References to CSA C22.3 No.9 have been transitioned out.</p>
4.0	November 2023 / (4.1) April 2024	<p>Updated guidance on UL1741 SA certification not being accepted. Updated requirements on not allowing oversizing of DER facilities. Added guidance on connections with pole breakers. Updated IPSC guidance. (4.1) Updated Annex A</p>
3.0	June 2023	<p>Updated Power Quality Voltage Requirements. Updated and Added PCC voltage regulation via power control. Added Annex A.</p>
2.0	October 2021	<p>Updated Shall Trip Requirements for Voltage Added Ride Through Requirements</p>
1.0	February 2019	Initial release

Table of Contents

REVISION HISTORY 3

1. SCOPE 5

2. NORMATIVE REFERENCES 5

3. GLOSSARY 6

4. INTERCONNECTION REQUIREMENTS 8

5. CONTROL AND MONITORING REQUIREMENTS 15

6. COMMUNICATION REQUIREMENTS 15

ANNEX A VOLTAGE RISE ASSESSMENT EXAMPLE 16

1. Scope

This document is prepared to assist DER owners understand their roles and responsibilities when connecting to the FAI electrical distribution system as a generator.

The requirements listed in this document apply to the following:

1.1. Single-Phase DER Systems less than or equal to 150kW

- Grid-following Inverter based
 - A certified unit or a certified system of units
- Micro cogeneration combined heat & power (CHP) based
 - Less than 150kW

NOTE – CHP generation require submission of a FortisAlberta Interconnection protection settings and Commissioning (IPSC) document.

1.2. Examples of such single-phase DER systems may include:

- Residential solar
- Commercial solar
- Combined heat & power (CHP)

1.3. This document does NOT apply to the following:

- Single-Phase DER systems greater than 150 kW and three-phase DER systems.
- Grid-forming Inverter based generation. For DERs that are Grid-Forming Inverter-based generation, a separate application shall be made to FortisAlberta.
- Inverter based systems that are not certified either as a unit or a system of units.
- Generators (Momentary Closed Transition) connecting momentarily (Parallel the distribution for 100ms or less) through automatic transfer switches (such as back-up / standby generators).

NOTE – For single-phase DER applications greater than 150 kW and three-phase DER systems, please refer to the document “DER-02 - FortisAlberta Technical Interconnection Requirements - DER 150kW and Greater” on the FortisAlberta’s [Website](#).

NOTE – For “Momentary Closed Transition” applications, please refer to the document “Interconnection Requirement Checklist - Standby or Backup Generator” on the FortisAlberta’s [Website](#).

2. Normative References

Knowledge of the following documents are prerequisites for these interconnection requirements. The documents shall be understood and followed, especially when cited in this document.

2.1. Interconnection Standards:

- CSA C235:19 – Preferred voltage levels for AC systems up to 50kV
- IEEE 1547-2018 – Standard for Interconnection and Interoperability of Distributed Energy Resources with Associated Electric Power Systems Interfaces
- Alberta 1547-2018 - IEEE 1547-2018 standard adjustments for the Province of Alberta, Canada
- C22.1 No. 1-2021 - Canadian Electrical Code (CEC), Part 1

NOTE – Ensure compliance with Rule 64-112 of the Canadian Electrical Code (CEC), Part 1, which governs photovoltaic (PV) size limitations for interconnection.

2.2. Equipment Standards:

- UL 1741 (2018) – Standard for Inverters, Converters, Controllers, and Interconnection System Equipment for Use with Distributed Energy Resources
- UL 1741 Supplement B – Test methods for advanced inverter functions

2.3. Other Technical Standards:

- IEEE 519-2014 – Recommended Practice and Requirements for Harmonic Control in Electric Power Systems
- IEEE 2030-2011 – Guide for Smart Grid Interoperability of Energy Technology and Information Technology Operation with the Electric Power System (EPS), and End-Use Applications and Loads
- NISTIR 7628 (2010) – Guidelines for Smart Grid Cyber Security

3. Glossary

Anti-islanding: a protective functionality aimed at preventing the continued existence of an unintentional electrical island (see “Islanding” below) to avoid safety concerns and potential damage to customer equipment.

Backup or emergency generator: An independent reserve source of electric energy that, upon failure or outage of the normal source, automatically provides reliable electric power within a specified time to critical devices and equipment whose failure to operate satisfactorily would jeopardize the health and safety of personnel or result in damage to property.

Certified: Tested and approved by an accredited certification organization such as CSA, UL, IEEE.

Cease to energize: Cessation of active power delivery under steady-state and transient conditions and limitation of reactive power exchange.

Distributed Energy Resource (DER): A source of electric power that is not directly connected to a bulk power system. DER includes both generators and energy storage technologies capable of exporting active power to an EPS. DER includes DG and MG.

Distributed Energy Resource (DER) system: The DER Unit's, interconnection systems, control systems, sensing devices or functions, and protection devices or functions up to the point of the DER connection.

Distributed Energy Resource (DER) unit: An individual DER device inside a group of DER that collectively form a system.

Distributed Generation (DG): Power generators that are connected to a distribution system through a Point of Common Coupling (PCC).

Distribution System: A system for distributing electricity, including any structures, equipment or other things used for that purpose. A distribution system is comprised of the main system capable of distributing electricity to many customers and the connection assets used to connect a customer to the main distribution system.

Electric Power System (EPS): Facilities that deliver electric power to a load.

Energize: Active power outflow of the DER to an EPS under any conditions (e.g., steady state and transient).

Export-Limited DER Configuration: A DER configuration where a certified PCS is used to limit active power export to the FortisAlberta distribution system to an approved export limit that is less than the DER facility nameplate rating.

FAI: FortisAlberta Inc.

Flicker: A perceptible change in electric light source intensity due to a fluctuation of input voltage. (In the context of power supply disturbances, the term applies to perceptible, subjective, objectionable, and random or periodic variations of the light output).

Harmonics: Sinusoidal voltages and currents at frequencies that are integral multiples of the fundamental power frequency which is 60 Hz in Alberta.

Inverter: A machine, device, or system that changes direct-current power to alternating-current power.

Islanding: A condition in which a portion of a transmission and/or distribution system is energized solely by one or more DERs, while that portion is electrically separated from the rest of the transmission or distribution system.

Micro Generation (MG): A DER system which meets the requirements of the Alberta Micro-Generation Regulation, Section 1(1)(h).

Measurement Point: The location where the interconnection performance requirements specified in this standard apply.

Momentary Closed Transition: A DER which parallels to the distribution system for less than 100ms.

Non-Export DER Configuration: A DER configuration where a certified PCS is used to prevent active power export from the DER system to the FortisAlberta distribution system at the approved measurement point.

Point of Common Coupling (PCC): The point of connection or demarcation point between the wire owner and the DER facility.

Point of Connection (PoC): The point of connection to where a DER unit is connected to a DER system.

Power Control System (PCS): A certified system that monitors and controls DER output, load, or other controllable equipment to maintain power export or import within defined limits at an approved measurement point.

Ride-Through: The ability to withstand voltage or frequency disturbances inside defined limits and to continue operating as specified

Synchronization: The state and operation where the DG facility is connected to the distribution system and supplies loads along with the electric grid.

Total Harmonic Distortion (THD): The ratio of the rms value of the sum of the squared individual harmonic amplitudes to the rms value of the fundamental frequency of a complex waveform.

Wire Owner: The entity who owns and/or operates a distribution system.

4. Interconnection Requirements

4.1. Measurement Point

The measurement location is the location where the DER system measures power system quantities for the purpose of implementing the protection and control functions required by this Standard.

- **Under 150 kW** – The measurement point may be between the point of common coupling (PCC) and the point of connection (PoC), as accepted by FortisAlberta. For DER systems using a PCS for export-limited or non-export configurations, the PCS shall control export at the approved measurement point.

4.2. Isolating Device

All DER systems shall follow the Canadian Electrical Code Part I and be capable of isolating from the distribution during maintenance and emergency conditions. (See Section 84 of CEC, Part I).

The physical location of the isolating device should (not mandatory) be in a location that is accessible to FortisAlberta staff. If the isolating device is not easily accessible to FortisAlberta staff, FortisAlberta reserves the right to disconnect the service completely (including load services) when necessary to conduct regular operations safely.

4.3. Interconnection Grounding

DG Systems shall be grounded as per manufacturer's recommendations and CEC Part I. Transformer grounding systems shall be coordinated with FortisAlberta and shall not cause voltage disturbances or disrupt coordination of distribution system ground fault protection.

4.4. DER Unit Certification

For all individual inverter systems and multiple inverter systems:

- UL 1741 SB certifications shall be required prior to energization.
- Only inverters which are certified may be connected to the distribution system.
- **Export Limiting Functions:** FortisAlberta accepts power control systems certified to UL 1741 CRD for PCS or UL 3141 for implementing export-limited DER configurations. The power control system shall be configured such that if the measured export power exceeds the approved export limit for more than 30 seconds, the power control system shall reduce DER output or cease exporting to maintain compliance with the export limit. DER systems that cannot reliably maintain their export-limited operation using a certified PCS may be subject to additional verification, monitoring, or mitigation requirements at FortisAlberta's discretion¹.
- **Non-Export Functions:** FortisAlberta accepts power control systems certified to UL 1741 CRD for PCS or UL 3141 for implementing non-export DER configurations. For non-export configurations, the PCS shall be configured to prevent active power export from the DER system to the FortisAlberta distribution system at the approved measurement point. The approved non-export setpoint shall be 0 kW export, unless otherwise approved by

¹ UL 3141 (Outline of Investigation for Power Control Systems) is the successor standard to the UL 1741 CRD for PCS and is the preferred certification pathway for new equipment. UL 1741 CRD for PCS certifications remain acceptable for equipment certified prior to the adoption of UL 3141.

FortisAlberta. If measured export power exceeds the approved non-export setpoint for more than 30 seconds, the PCS shall reduce DER output or cease exporting to re-establish the non-export condition. DER systems that cannot reliably maintain non-export operation using a certified PCS may be subject to additional verification, monitoring, witnessed testing, or mitigation requirements at FortisAlberta's discretion.

- Fail-Safe Requirement for UL 1741 CRD for PCS or UL 3141: In the event of a PCS fault, loss of metering signal, or loss of communication required for the PCS control function, the PCS shall default to a fail-safe state that prevents export above the approved export limit or approved non-export setpoint. For non-export configurations, the fail-safe state shall prevent export to the FortisAlberta distribution system. DER systems that cannot demonstrate this fail-safe behaviour shall not be accepted for export-limited or non-export configurations. The fail-safe behaviour shall be demonstrated during commissioning and documented in the project record.

4.5. DER Facility Ratings

4.5.1. Oversizing of DER Facilities

The DER owner shall not be permitted to size their DER plant above the capacity specified in the interconnection agreement. The DER plant rating shall be the sum of the nameplates of the individual DER units (e.g., 5x10 kVA inverters shall be a plant rating of 50 kVA).

4.5.2. Guidance on Pole Breakers

Microgenerators connecting to services with pole breakers are only permitted to use up to 80% of the rated breaker ampacity. Guidance shall be provided by FortisAlberta on connections subject to pole breaker limitations.

4.6. DER Aggregation Requirements

If multiple DERs are proposed for connection by the same or similar customer within the same geographical area or feeder, FortisAlberta may, at its sole discretion, aggregate these DERs into a single site for the purposes of connection assessment, management, or interconnection requirements. E.g. a customer applies for three separate single phase DER connections, each with a capacity of 100 kW, and these connections are on the same feeder and different phases, the utility may aggregate these applications into a single three-phase 300 kW DER for evaluation and connection purposes.

4.7. Power Quality (Technical specifications and performance requirements)

4.7.1. Design and Calculation of Voltage Levels

DER owner is responsible for the design and calculations of voltage levels of the DER system up to the PCC. The voltage at the PCC shall comply to the range specified in CSA C235. This applies to both primary and secondary voltage where the concern is multiple customers off the same feeder or service transformer.

4.7.2. Expected Operating Voltage from the Utility

The expected operating voltage from the utility (FortisAlberta) is normally regulated at 104% of nominal voltage at the PCC but will be at 106% (extreme operating limits per CSA 235) with other DERs connected to the distribution system. The customer is required to take the extreme operating limits into consideration when performing voltage calculations or sizing the DER

system. (The expected operating voltage may change due to system dynamic characteristics and future voltage support distribution technologies)

4.7.3. DER Owner Responsibilities

- The customer is responsible for ensuring that the voltage at the DER equipment, such as the inverter, does not exceed the voltage trip requirements to avoid potential nuisance tripping.

NOTE – The secondary conductor, whether overhead or underground, running between the service entrance and the inverters, can cause voltage rise with reverse power, with the highest voltage typically observed at the DER AC terminals.

- The customer shall calculate secondary voltage rise and consider potential nuisance tripping caused by overvoltage during the design phase of the DER interconnection. It's important to understand that Farm, Irrigation, or Rural/Residential services are more likely to be affected by overvoltage, so they need special attention when addressing voltage rise and nuisance tripping.
 - Please refer to **Annex A** for an informational example on voltage design.

4.7.4. Low voltage DER Interconnection SLD

The single line diagram in Figure 1 shows a typical interconnection of a DER system to a low voltage distribution system through a distribution transformer. Conductor type and length up to the service entrance; DER type and size; are all required and identified as a part of the SLD submitted with the application. This information will help to model and calculate issues concerning voltage rise which may need to be mitigated.

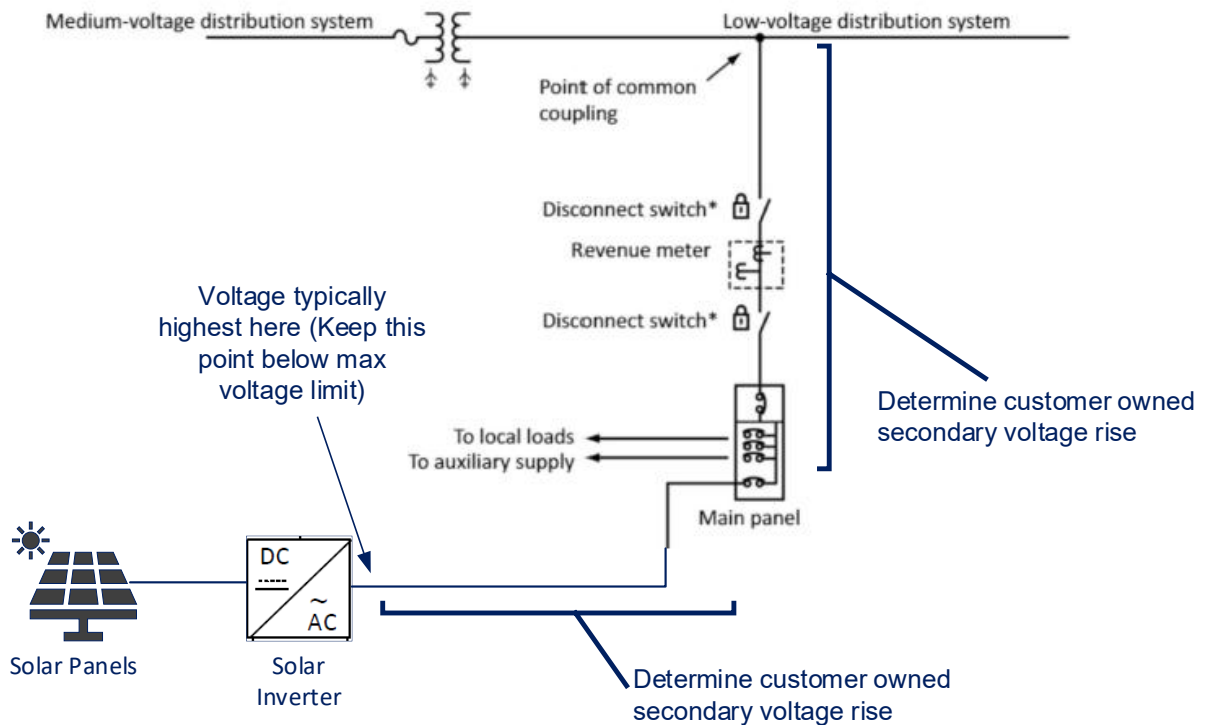

Figure 1 - Interconnection of a DER system to a low-voltage distribution system with a distribution transformer

Measurements to verify compliance as it relates to the CSA C235-19 shall be conducted either at the service entrance or at the Point of Common Coupling (PCC), whichever is easily accessible. For measurement purposes, in most cases is the metering point, however where site access is restricted, FortisAlberta reserves the right to choose an accessible location to measure closest to the service entrance or the metering point.

4.7.5. Harmonic Distortion

Harmonic current distortion shall comply with the limits from IEEE 1547-2018. Current total harmonic distortion (THD) shall not exceed 5% of rated current.

4.7.6. DC Current Injection

The DC current injection shall not exceed 0.5% of the full rated output current at the measurement point.

4.8. Reactive Power Capabilities

DER systems shall be capable of sourcing (injecting, over-excited, capacitive) and consuming (absorbing, under-excited, inductive) reactive power, Q up to levels within the range of values as indicated below at all PCC feed-in active power, P levels from 20% of corresponding DER nameplate kVA rating and onward.

4.8.1. Minimum DER System Reactive Power Capabilities

- Sourcing (capacitive) and Consumption (inductive) Capability as % of as Nameplate Apparent Power, S (kVA) Rating
- 44% over +/- 5% of PCC nominal voltage range [corresponding to Category B requirements in IEEE 1547-2018](#).

NOTE – 44% is equivalent to a power factor range of ± 0.9 (i.e., 0.9 lagging and leading)

4.9. PCC voltage regulation via power control

4.9.1. Voltage Regulation Capabilities

DER systems shall be capable of voltage regulation at the PCC via DER system autonomous power control that meet the requirements within IEEE 1547-2018.

NOTE – The default control function enabled shall be adjustable constant power factor control with a power factor set point of 1.0.

4.9.2. DER Autonomous Functions and Capabilities

The DER system shall be capable of PCC voltage control provision via following DER system autonomous functions/modes:

- Constant power factor
- Voltage – reactive power (volt-var)
- Active power – reactive power (watt-var)
- Constant reactive power
- Voltage – active power (volt-watt)

4.9.3. Setting Modifications

The DER operator shall be responsible for implementing setting modifications and control function selections, as specified by FortisAlberta. Under mutual agreement between

FortisAlberta and DER operator, reactive power control functions and their implementations other than the ones listed above shall be permitted².

4.9.4. Setting Modifications (in effect Q1 2027)

All DER systems shall enable voltage - active power control (Volt-Watt) as defined by IEEE 1547-2018. The Volt-Watt function shall be configured with the following default settings, unless otherwise approved by FortisAlberta³:

- V1 = 107% of nominal voltage, P1 = 100% of rated active power
- V2 = 110% of nominal voltage, P2 = 0% of rated active power

Between V1 and V2, the DER active power output shall be reduced linearly from P1 to P2. For voltages below V1, the DER may operate at rated active power. The default Volt Watt characteristic is illustrated in Figure 2 – Default Volt Watt Control Curve.

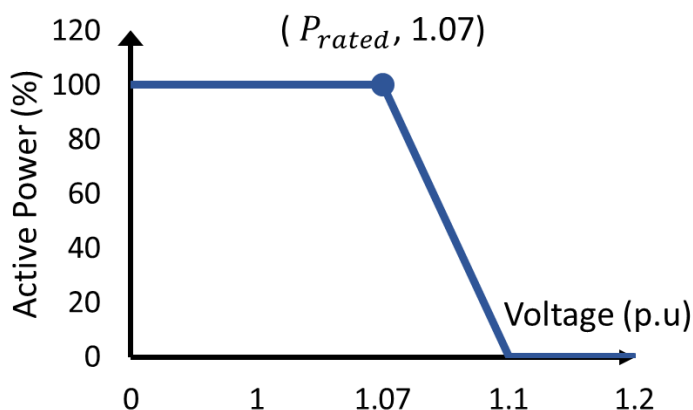

Figure 2 – Default Volt Watt Control Curve.

² While the advance grid support functions/modes listed above may not be enabled at commissioning, when the EPS or the power quality at PCC is negatively impacted, FortisAlberta reserves the right to enable or adjust the DER control modes to achieve acceptable levels.

³ The default Volt Watt curve assumes a voltage rise of approximately 1% from the PCC to the PoC. If the voltage rise assessment conducted by the DER owner indicates a voltage rise greater than 1% between the PCC and the PoC, the DER owner or installer shall contact FortisAlberta for further assessment and direction. FortisAlberta may require adjusted Volt-Watt settings or additional mitigation measures to maintain acceptable voltage levels on the distribution system.

4.10. Technical Protection Requirements

4.10.1. Shall Trip Requirements

All DER Units shall comply with the voltage and frequency ride-through requirements for Category II for inverter interfaced generation or doubly fed induction generation and Category I for synchronous and induction generation as per Section 6.4 and 6.5 of IEEE 1547-2018.

Table 1 – Voltage Trip Requirements

Inverter-Based Generation			Machine-Based Generation		
Trip Function	Voltage (% of nominal voltage)	Clearing Time (s)	Trip Function	Voltage (% of nominal voltage)	Clearing Time (s)
OV3	120	0.16	OV3	120	0.16
OV2	110	2	OV2	110	2
UV1	88	10	UV1	88	2.0
UV2	45	0.16	UV2	45	0.16

Table 2 – Frequency Trip Requirements

Trip Function	Frequency (Hz)	Clearing time (s)
OF2	62.0	0.16
OF1	61.2	300.0
UF1	58.5	300.0
UF2	56.5	0.16

- All DER systems shall cease to energize and trip when a fault is detected on the distribution system.

4.10.2. Ride Through Requirements

All DER Units shall comply with the voltage and frequency ride-through requirements for Category II for inverter interfaced generation or doubly fed induction generation and Category I for synchronous and induction generation as per Section 6.4 and 6.5 of IEEE 1547-2018.

Note – The design criteria shall match the default minimum ride-through time (s) and maximum response time (s) identified in IEEE 1547-2018.

4.10.3. Anti-Islanding

Inverter based generation shall meet the anti-islanding requirements of UL 1741 SB

- All other forms of generation shall cease to energize and trip within 2 seconds of the formation of an island.
- [Guidance on Islanding Group Configurations: FortisAlberta’s review of DER interconnection projects has shown that inverters equipped with Sandia Group 1 or Group 2A anti-islanding methods typically integrate more effectively with the distribution system, reducing the likelihood that additional system upgrades or mitigation measures will be](#)

required. DER proponents are encouraged to consider these inverter configurations early in the design process. Projects that utilize other islanding groups or methods may be subject to more stringent mitigation requirements at FortisAlberta's sole discretion.

4.10.4. Return to Service after Trip

After ceasing to energize the distribution system due to any abnormal condition, the DER system shall wait 300 seconds before attempting to reconnect.

4.10.5. Enter Service

The DER facility shall meet the enter service and synchronization requirements from IEEE 1547-2018 (Section 4.10.2). Default settings shall be used unless otherwise specified by FortisAlberta, with the exception that the maximum applicable voltage shall be 1.06 per unit.

4.10.6. Synchronization

The synchronization or interconnection process for any DER system shall not create a voltage drop greater than 5% and shall, at the measurement point, meet the flicker requirements of CAN/CSA 61000-3-5 (Low Voltage) and CAN/CSA 61000-3-7 (Medium Voltage).

4.10.7. FortisAlberta Interconnection Protection Settings and Commissioning (IPSC) Document

Non-Inverter generation requires the submission of a FortisAlberta IPSC document. Please use the IPSC document template on the FortisAlberta Website.

FortisAlberta may require an IPSC to be submitted for inverter-based generation subject to their discretion.

4.10.8. Power Control System (PCS) Commissioning Record

For DER systems utilizing a PCS for export-limited or non-export configurations, the applicant shall submit the PCS Commissioning Record in accordance with FortisAlberta's staged PCS commissioning process. Stage 1 information shall be submitted and accepted prior to scheduling commissioning activities, and completed commissioning results shall be submitted for FortisAlberta review and acceptance prior to interconnection processing. The record shall demonstrate that the PCS has been configured, tested, and documented to maintain the approved export limit or approved non-export setpoint at the approved measurement point. The PCS Commissioning Record shall include the following:

- PCS make, model, certification number, and applicable certification basis, being UL 1741 CRD for PCS or UL 3141, confirming the PCS is certified for the proposed operating mode, being export-limited or non-export.
- Configured export limit or approved non-export setpoint, as applicable. For non-export configurations, the approved setting shall be 0 kW export at the approved measurement point, unless otherwise approved by FortisAlberta. The record shall confirm that the settings have been applied and locked in accordance with the manufacturer's instructions.
- Results of a fail-safe test demonstrating that, upon interruption of the metering signal or loss of PCS communications required for the PCS control function, the PCS prevents export above the approved export limit or approved non-export setpoint. For non-export configurations, the record shall demonstrate zero export at the approved measurement point. The record shall identify the signal interrupted, the method of interruption, and include timestamped evidence, such as a PCS interface screenshot or data log, confirming the fail-safe response.

- The standard PCS commissioning test set includes fail-safe, islanding, return to grid, and export limit control testing, unless otherwise accepted by FortisAlberta.
- FortisAlberta reserves the right to witness testing of the PCS fail-safe function during commissioning at its discretion, including where the PCS architecture is non-standard, where the DER system is near or above applicable study thresholds, or where prior PCS performance concerns have been identified.

5. Control and Monitoring Requirements

5.1. DER Facility shall have the provision for monitoring the isolation device at the PoC.

A SCADA link and modem to FortisAlberta’s network is not required but may be requested at a later date.

Monitoring data requirements shall comply with IEEE 1547-2018 (Section 10) for all available data points. Minimum required data points which FortisAlberta may request are currently the following:

Table 3 – Minimum Required Data Points

Minimum Required Data Points	
Active Power (W)	Reactive Power (Var)
Voltage (V)	Frequency (Hz)
Operational State (Generation On or Off, Operational Mode)	Connection Status
Alarm Status	Operational State of Charge (if applicable)

Note – All DER monitoring requirements of IEEE 1547 shall be available through a DER unit to make available for future monitoring and control.

6. Communication Requirements

The DER system shall be capable of providing real-time operating information to FortisAlberta from an intelligent electronic device (micro-processor relay, inverter, etc.). When deemed applicable by FortisAlberta, a communication interface module may be supplied by FortisAlberta for real-time control and/or monitoring.

Table 4 – Eligible Protocols

Eligible Protocols (IEEE 1547)		
Protocol	Transport	Physical layer
IEEE Std 2030.5 (SEP2)	TCP/IP	Ethernet
IEEE Std 1815 (DNP3)	TCP/IP	Ethernet
SunSpec Modbus	TCP/IP	Ethernet
	N/A	RS-485

Annex A Voltage Rise Assessment Example

A1. This section serves as an assessment guide and example to account for the voltage rise issue when designing the MG system. The example demonstrated below shows a typical scenario or system setup. The result of this assessment indicates there is an overvoltage condition present at inverter location, so it may trip off frequently. An overvoltage condition is also present at the point of common coupling that may impact other customers. Mitigations are required by the customer.

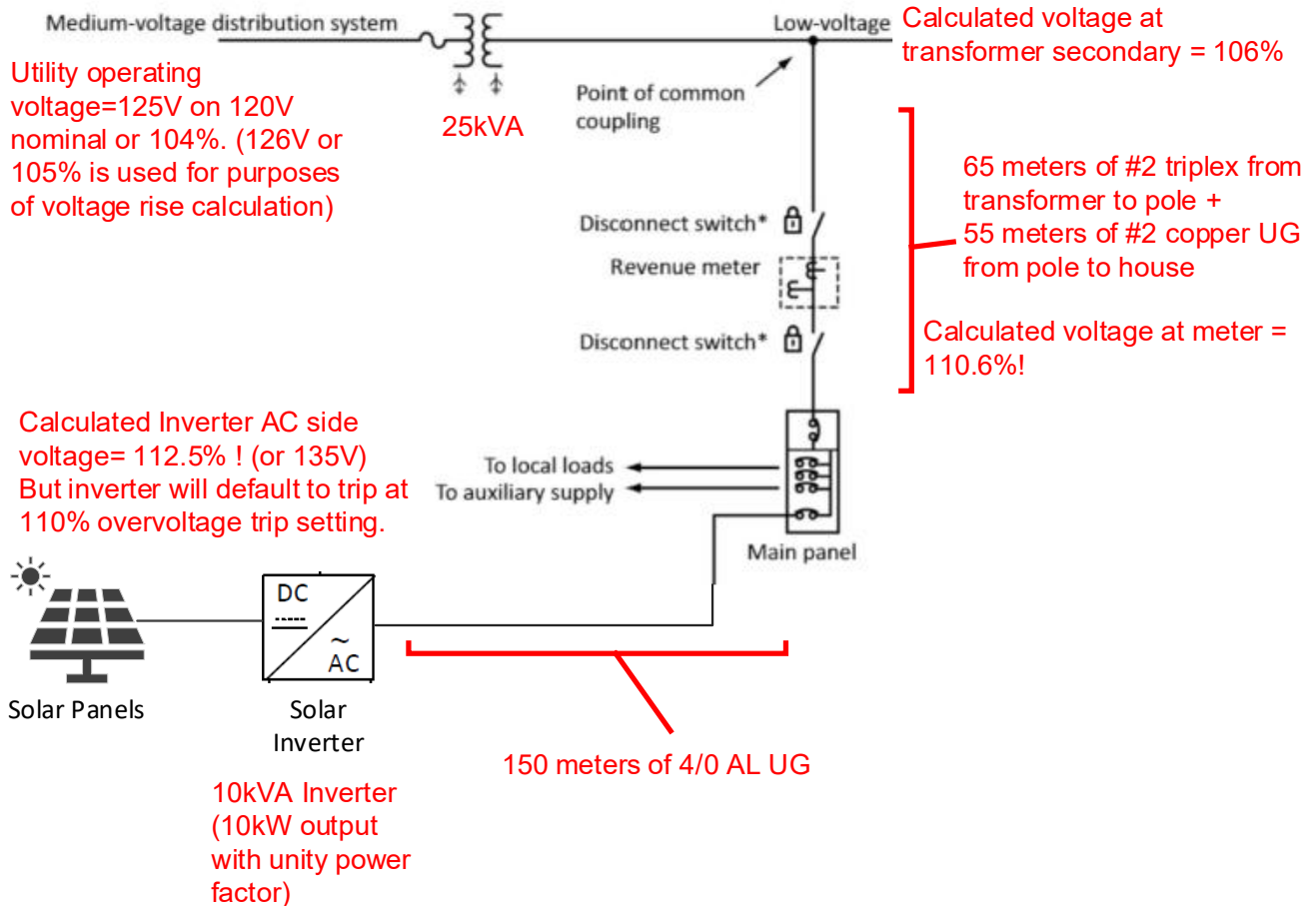

Figure 3 - Secondary voltage rise example with small MG system