



# **CUSTOMER INSTALLED PRE-CAST BASE, GROUNDING, AND DUCTING**

**Version No: 5.2**

**August 10, 2023**

**FORTIS  
ALBERTA**

Copyright © 2023 FortisAlberta. All rights reserved. No modifications or reproductions are allowed without written permission.

Printed on Oct. 17, 2023 at 11:52 AM. The current revision is on FortisAlberta Standards Database.

**Table of Contents**

1. SCOPE AND PURPOSE .....	3
2. SERVICE CLASSIFICATIONS.....	3
3. PRE-REGISTERED DESIGN CONSULTANTS AND CONSTRUCTION CONTRACTORS .....	4
4. GLOSSARY .....	4
5. CIPGD PROCESS STEPS.....	4
6. DRAWING REQUIREMENTS .....	7
7. DESIGN & INSTALLATION GUIDELINES .....	8
8. MATERIAL STANDARDS AND SPECIFICATION .....	14
9. INSPECTION AND TESTING .....	17
ANNEX A REVISION HISTORY (INFORMATIVE).....	18
ANNEX B FORMS AND REFERENCE (INFORMATIVE) .....	20
ANNEX C SERVICE AND METERING GUIDE, CONDUIT SYSTEMS (NORMATIVE) .....	46
ANNEX D SERVICE AND METERING GUIDE, SECTION 15.4 (NORMATIVE) .....	49
ANNEX E SERVICE AND METERING GUIDE, SECTION 15.5 (NORMATIVE) .....	51

**1. Scope and Purpose**

- 1.1. The Customer Installed Pre-Cast Base, Grounding, and Ducting (CIPGD) Process offers the ability for customers to install the pre-cast base, grounding, and ducting, specific to the customer's electric service requirements, within their development. This will allow the customer to manage the proper installation of pre-cast base, grounding, and ducting within their control. However, the CIPGD process should be followed diligently for the efficient installation of these facilities.
- 1.2. The Customer Installed Pre-Cast Base, Grounding, and Ducting (CIPGD) Process is applicable to single property developments (i.e., general service/commercial, industrial, oil & gas, commercial complex, malls, bare land commercial developments, apartment buildings, recreational vehicle parks, etc.) with one or multiple electric service requirements.
- 1.3. The CIPGD process covers FortisAlberta's general requirements for the design and installation of underground electrical distribution system facilities on customer property. This includes cable ducts, transformer bases, grounding, etc. These facilities are to be installed by the customer and are to be inspected and accepted by FortisAlberta. FortisAlberta will proceed to install the primary cables and transformer for the customer. These facilities will be energized and maintained by FortisAlberta.
- 1.4. Multiple property developments (i.e., Commercial, and Industrial subdivisions) are excluded in this CIPGD process.
- 1.5. The design and installation of Underground Electrical Distribution Systems (UEDS) on residential developments and bare land developments are excluded in this process and shall follow the requirements provided in FortisAlberta's UEDS manuals.
- 1.6. All requirements related to metering are not part of this document. Please refer to the FortisAlberta Service & Metering Guide (SMG) on [www.FortisAlberta.com](http://www.FortisAlberta.com). This document is meant to complement the FortisAlberta's Service and Metering Guide and in no way overrides it.
- 1.7. Farm, Irrigation, and Rural Residential services are excluded in this process. FortisAlberta will install the underground electrical distribution systems on Farm, Irrigation, and Rural Residential services.

**2. Service Classifications**

- 2.1. Simple Services - services are classified as *Simple Services* when all the following apply:
  - One pad-mounted transformer is servicing one site.
  - Length of duct is less than 150 m and has combined deflections (sweep or bend) less than 90° (excluding the bend inside the transformer pad).
  - There are no crossings and/or proximities with other facilities that require approvals (pipeline crossings, etc.).
  - Lot is up to final grade ( $\pm 150$  mm).
- 2.2. Complex Services - all services that do not satisfy the *Simple Services* requirements above.

### **3. Pre-Registered Design Consultants and Construction Contractors**

#### 3.1. Use of Pre-registered Design Consultants and Construction Contractors

The FortisAlberta list of [pre-registered design consultants and construction contractors](#) is available in the FortisAlberta.com website.

The use of design consultants is mandatory for designing *Complex Services*. For *Simple Services*, the use of design consultant is optional.

The construction and installation of pre-cast base, grounding, and ducting in the CIPGD process shall only be performed by the construction contractors listed on the FortisAlberta pre-registered list.

#### 3.2. Pre-registration Process

FortisAlberta's pre-registration process is required for companies to do work for FortisAlberta.

Design consultants and construction contractors who want to obtain more information on our pre-registration process or who want to be listed to be able to do work for FortisAlberta can apply to our Contract Services group through e-mail [contracts@FortisAlberta.com](mailto:contracts@FortisAlberta.com) or by fax at (403) 514-5981.

### **4. Glossary**

**AFC:** Customer Approved For Construction drawing.

**BOM:** Bill of Material

**Duct/conduit:** Terms used interchangeably for plastic, metal or PVC tubing used to encase underground conductor.

**Offsite work:** The work required outside of the customer's property to get the customer's electric service connected to FortisAlberta's electric distribution system. FortisAlberta will complete the offsite work.

**Red-line** Records of all construction deviations from AFC drawing.

**Record drawing:** Authenticated drawing created to record design changes for which the professional member has accepted responsibility.

**SMG:** FortisAlberta Service & Metering Guide

**Transformer or cubicle base/pad:** Terms used interchangeably for pre-cast concrete bases used to mount a switching cubicle or padmount transformer or MVI.

**UEDS:** Underground Electrical Distribution System

### **5. CIPGD Process Steps**

The CIPGD Process is provided in detail below. The customer is responsible to follow the CIPGD process.

All work associated with fixing deficiencies in customer installations, such as exposing of already installed customer facilities due to improper installation and premature backfilling, is to be completed by the customer at their expense. As such, compliance to the CIPGD process is needed.

A flow chart outlining the CIPGD process can be found in Annex B, Item 13.

#### 5.1. Initial Contact

Customer calls 310-WIRE (9473) or fills out an online new customer service connections application form to request a new power service or a change to an existing service. The online application form for all service types can be found under "[Get Connected](#)" on [www.FortisAlberta.com](http://www.FortisAlberta.com).

#### 5.2. New Service Quote

The customer submits a copy of the most recent site plan showing all utilities, buildings, transformer locations, ducting route (include burial depth), existing/proposed above and underground facilities, deep (water/sewer) services, dimensions of the property site and buildings, customer construction schedule and required connect date.

A site meeting with a FortisAlberta representative may take place as required. The scope of work for the new service is estimated by FortisAlberta and a quote letter package is sent out to the customer.

#### 5.3. Customer Acceptance

The customer reviews quote, approves, and makes payment, as required.

#### 5.4. Design: Preliminary Review/Meeting

FortisAlberta contacts the customer and determines the type and location of any offsite work or facilities that FortisAlberta must perform or provide.

Preliminary design drawings and details are reviewed with the customer and/or pre-registered design consultant. FortisAlberta determines which category the new service will fall under: *Simple or Complex Service*.

FortisAlberta provides the customer and/or pre-registered design consultant with FortisAlberta minimum design standards and any other details the customer may need, to follow design standards and safe construction practice.

The customer and/or pre-registered design consultant supplies Approved for Construction (AFC) drawings as soon as practical after review/meeting. The AFC drawings must show details of the transformer base, grounding, guard posts (bollards), location of pads relevant to buildings, proposed final grades along the duct alignment and at all transformers/equipment, driving services, and other above and underground facilities. All drawings should be marked as AFC.

The customer also supplies construction schedule and required connection date.

Installation of ducting, transformer pad and grounding must not begin until AFC drawings have been accepted by FortisAlberta.

**Applicable only for *Complex Services*:**

Cable pulling calculations are required from the customer/pre-registered design consultant if it is considered *complex*. A pull is considered *complex* if the length of duct is greater than 150 m or has combined deflections (sweep or bend) greater than or equal to 90° (excluding the bend to the transformer pad).

A [Cable Pulling Analysis \(CPA\) calculator](#) and [documentation](#) based on the standard FortisAlberta cable, duct data and pulling methods are available to FortisAlberta pre-registered consultants.

For complex services, AFC drawings must be signed and stamped by the pre-registered design consultant's engineer. The AFC drawings will include proposed final grades along the duct alignment and at all transformers/equipment.

If any work is done without curb and gutter installation, the [Application for Installation without Curbs and Gutters](#) in Annex B must be completed and signed.

The Design Consultant is responsible for obtaining all required third-party approvals for installation of facilities on customer site.

The consultant should also provide installations within Registered Easements and or Utility-Right-of-Ways (URW) when required.

**5.5. Final review and Approved for Construction (AFC) approval.**

FortisAlberta reviews any requested changes and accepts the AFC. Once the AFCs are approved, FortisAlberta releases offsite work construction packages in addition to the work needed within the development.

The customer/pre-registered design consultant is responsible for contacting FortisAlberta if any changes are proposed after the AFC is issued; all post-AFC changes must be approved by FortisAlberta.

The customer/pre-registered design consultant must arrange for a pre-registered contractor to install the pre-cast base, ducting and grounding within the development. In addition, a copy of the FortisAlberta approved AFC shall be provided to the pre-registered contractor.

To avoid rework, AFC drawings shall first be approved by FortisAlberta prior to any installations are performed within the development.

**5.6. Construction**

Only pre-registered construction contractors shall install pre-cast bases, ducting, and grounding.

The pre-registered contractor is to call 310-WIRE (9473) five (5) working days prior to the backfill of any underground facilities to arrange an inspection by FortisAlberta.

The pre-registered contractor is required to follow all specifications laid out in the AFC drawing and in the FortisAlberta Services and Metering Guide, as well as all applicable legislation and codes, in which case the former will supersede in all cases. Failure to meet these requirements may result in a service delay.

Site grade management is the responsibility of the customer (and consultant for complex services), including grade adjustments that may be required to ensure proper cable depths and equipment placement.

All trench and grade stakes shall be installed along the proposed alignment and at equipment locations. These stakes need to be in place prior to a FortisAlberta Crew Lead/Unit Price Area Coordinator inspection. Once the inspection is completed, it normally takes two to three weeks for the FortisAlberta construction to take place.

All changes made to AFC drawings during construction must be made with “red lines”.

**Applicable only for Complex Services:**

During the installation of the work, the elevations along the top of duct and equipment locations shall be captured and recorded accordingly. Trench depth shall be managed throughout the installation.

After installation of the work and prior to energization, the customer and their consultant shall provide a grading as-built plan, showing the actual ground elevation after backfilling and the recorded elevations along the top of the installed duct and at all underground equipment pad locations. The grading as-built plan should show the difference between the actual ground elevation after backfilling and the recorded elevations of the installed duct to be within 1.0 m to 1.2 m for standard trench and 1.2 m to 1.5 m for road crossings. Similarly, the top of the equipment pad to be within 150 mm from the actual ground elevation after backfilling.

NOTE: The actual ground elevation after backfilling shall be within  $\pm 150$  mm (6 inches) of the proposed final grade elevation. Upon submission of the grading as-built plan, no other excavation work (i.e., cutting, fill) shall be made along the installed facilities without a written consent of the FortisAlberta Crew Lead/Unit Price Area Coordinator.

This grading as-built plan must be submitted to the FortisAlberta design specialist for approval. Once the design specialist has reviewed and accepted the final grade plan the FortisAlberta field employee will be notified that energization of the site may proceed.

FortisAlberta reserves the right to have the customer perform hydrovac at locations as deemed appropriate and witnessed by the FortisAlberta Crew Lead/Unit Price Area Coordinator to confirm that the actual set depths of the ducts/cables and underground facilities and equipment locations meet FortisAlberta’s construction standards.

**5.7. Contact Retailer**

The customer contacts the retailer to request a meter connection. A quote letter with service information is required (including civic address or legal land location, and site ID), along with billing information.

**5.8. Meter Connection**

The connection and installation of metering occurs only after the FortisAlberta construction (on and off-site) is completed.

**6. Drawing Requirements**

The standard requirements for the engineering drawings and detailed plans submitted to FortisAlberta by the consultant are in the following clauses.

**6.1. Drawing Issued for FortisAlberta Acceptance**

Drawings issued for acceptance must be authenticated (exceptions made for *Simple Services*) and include signing block or stamp with space for FortisAlberta's acceptance.

6.2. Approved for Construction (AFC) design drawings must include:

- Locations and installed depth of ducts - include alignments. Details of ducts complete with cable pulling lengths and tensions.
- Cable pulling calculations are to be provided to FortisAlberta.
- Location of transformer pads relevant to buildings, driving surfaces, other aboveground facilities - e.g., fire hydrants and/or known underground facilities (Alberta One-Call markings)
- Blast wall and guard post requirements, as required.
- Proposed final grades along trench alignment and at all transformers/equipment locations.
- Property lines and ties to legal pins
- Metering connection points
- Locations of any 3<sup>rd</sup> party pipeline crossings, road crossings and/or other rights-of-way affecting customer on-site work and FortisAlberta cable routes on-site.

6.3. As-built Drawings Issued for FortisAlberta Commissioning

"Red Lines" must be used to identify any revisions made to the AFC prints during construction. These will be used to create the as-built plans of the installation. The contractor must maintain accurate "red line" information and records of all construction as work progresses. This includes all changes to engineering drawings and other concealed services. It also includes the measured equipment ground electrode test results, top of duct grades, final backfilled grades along trench and at equipment as well as the "red-line" information must be neatly noted on all plans – where applicable include overlapping detail as well as the composite plan. "Red-Line" as-built drawings do not need to be authenticated by the consultant's engineer.

NOTE: The consulting engineer will have reviewed and approved all "red line" information prior to the noted field changes being made. Where significant changes have occurred, the changes are required to have been communicated and coordinated, with FortisAlberta prior to the changes actually occurring (as required by the situation).

6.4. Record Drawings Issued to FortisAlberta

Record Drawings will be required if there are significant changes on the "red-line" as-built drawing. The significance of the changes will remain under FortisAlberta discretion. The "Record Drawings" are created to record design changes for which a professional member has accepted responsibility. They must be authenticated and should be stamped "Record Drawings", and all "red-line" as-built information will be superimposed on the original design drawings, recorded in the revisions title block, and prepared with the final drawing.

## **7. Design & Installation Guidelines**

All installations will be in accordance with the FortisAlberta accepted AFC drawings, and the material and construction standards and specifications provided in this publication. A FortisAlberta representative must be met with on-site prior to proceeding with installation. In



cases where a conflict or discrepancy exists between the construction and detailed engineering drawings provided or the requirements of this document, the latter will take precedence and will govern the installation. In the event of discrepancies, any ambiguity must be referred to the FortisAlberta designer prior to proceeding with that phase of the installation.

### 7.1. Foundations

- a) Top of pad is to be 150 mm (6") above final grade.
- b) Minimum vertical clearance from top of pad to any fixed structure shall be no less than 3.9 m (12'10").
- c) Transformer pad spacing from walls must meet requirements outlined in the FortisAlberta's Service and Metering Guide and as provided in detail below:
  - A 4.0 m clear working space must be provided on the access side of a transformer.
  - For three-phase transformers rated greater than 3000 kVA, a minimum separation of 6.0 m is required from any wall with door, window, and/or vent; or 3.0 m from any combustible wall or 1.5 m from a non-combustible wall is required other than the access side of the transformer.
  - For three-phase transformers rated 3000 kVA and below, a minimum of 1.5 m separation is required from all other sides (other than the access side) of the transformer.
  - Refer to drawing [SMG 7.1, Commercial Services Location of Padmount Transformers](#)
- d) The slope or grade on which the transformer base sits and the 4.0 m operating area in front of the padmount transformer's access lid must be less than 9.5° or less than a 1:6 slope (i.e., 1 m rise in 6 m run).
- e) Minimum distance from the edge of the pad to any property line shall be 1.0 m (3'3").
- f) The pre-cast concrete base shall be installed on level, well compacted soil, and filled with a minimum of 150 mm (6") compacted gravel. It is preferable to use washed gravel over other types of gravel.
- g) A soil bearing capacity calculation shall be done to ensure that the combined weight of the transformer and the concrete base does not result in slumping of the transformer and concrete base. See Table 1 for the combined weight for a transformer and pre-cast concrete base.
  - Not to be placed on soils that are in class 8 (wet, peat) without special foundation. When foundation support (e.g., foundation piles) is required, it needs to meet the weight requirements of the equipment on the pad. Grounding requirements clause 5.2 must be followed. See Table 1 for sample weights.
  - Single phase transformers (up to 167 kVA using 755-0505 base), three phase transformers (75 kVA to 500 kVA using 755-0507 base), switching cubicles (using 755-0557), and MVIs (using 755-0570) shall use pressure treated 2" x 8" planks. The treated plants shall be installed in the gravel bed under the footing of the concrete base and for leveling prior to the installation of the pre-cast concrete base.

### 7.2. Weight of padmounted equipment with concrete base

Approximate weight of the pad-mounted equipment (i.e., transformer, Switching Cubicle, and MVI) with concrete base are provided in Table 1.

Table 1: Weight of pad-mounted equipment with concrete base

Equipment (Primary Side 25 kV)	Concrete Base Type	Total Weight with Concrete Base [kg]	Use Planks	Base Area [m <sup>2</sup> ]	Soil Bearing Pressure [kPa]
Mini-Pad ≤ 167 kVA	755-0505 (1-Phase)	1435	Yes	0.846	16.63
208-600V - 75 KVA	755-0507 (3-Ph ≤ 500 kVA)	3858	Yes	1.403	26.96
208-600V - 150 KVA	755-0507 (3-Ph ≤ 500 kVA)	4176	Yes	1.403	29.18
208-600V - 225 kVA	755-0507 (3-Ph ≤ 500 kVA)	4267	Yes	1.403	29.82
208-600V - 300 kVA	755-0507 (3-Ph ≤ 500 kVA)	4601	Yes	1.403	32.15
208-600V - 500 kVA	755-0507 (3-Ph ≤ 500 kVA)	5108	Yes	1.403	35.70
208-600V - 750 kVA	755-0512 (3-Ph 750-3000 kVA)	8135	No	1.800	44.32
208-600V - 1000 kVA	755-0512 (3-Ph 750-3000 kVA)	8401	No	1.800	45.77
208-600V - 1500 kVA	755-0512 (3-Ph 750-3000 kVA)	8701	No	1.800	47.40
208-600V - 2000 kVA	755-0512 (3-Ph 750-3000 kVA)	10300	No	1.800	56.12
208-600V - 2500 kVA	755-0512 (3-Ph 750-3000 kVA)	11170	No	1.800	60.86
208-600V - 3000 kVA	755-0512 (3-Ph 750-3000 kVA)	12010	No	1.800	65.43
208-600V - 4000 kVA	755-0516 (4160V 1-20 MVA)	17687	No	2.958	58.65
4160V - 1000 kVA	755-0516 (4160V 1-20 MVA)	11550	No	2.958	38.30
4160V - 1500 kVA	755-0516 (4160V 1-20 MVA)	12530	No	2.958	41.55
4160V - 2000 kVA	755-0516 (4160V 1-20 MVA)	13040	No	2.958	43.24
4160V - 2500 kVA	755-0516 (4160V 1-20 MVA)	14440	No	2.958	47.88
4160V - 3000 kVA	755-0516 (4160V 1-20 MVA)	15400	No	2.958	51.06
4160V - 5000 kVA	755-0516 (4160V 1-20 MVA)	18735	No	2.958	62.12
4160V - 7500 kVA	755-0516 (4160V 1-20 MVA)	23072	No	2.958	76.50
4160V - 10000 kVA	755-0516 (4160V 1-20 MVA)	27070	No	2.958	89.76
MVI (2-Way)	755-0570	2853	Yes	1.115	25.10
Switching Cubicle or MVI (4-Way)	755-0557	3758	Yes	1.588	23.21

### 7.3. Grounding

- a) All grounding must meet the requirements of the Alberta Electric Utility Code, 2022 Edition, clause 12-002 (5) (clause 15.9) requirements and the requirements in Table 2 below.
- b) The design of the padmount Transformer ground electrode and gradient control grid should be determined by the FortisAlberta designer - single or three loop gradient control grid. For single phase transformer see [Drawing 1226](#). For a three-phase transformer refer to [Drawing 1315](#).

- c) The customer must install the required ground electrode and gradient control grid, accordingly.
- All ground electrodes must be tested before connecting the concentric neutrals using the “Three-Point Method” or “Fall of Potential” to meet the maximum resistance per grounding electrode values as listed in Table 2 for each pad mount equipment (transformer, switching cubicle, MVIs, etc.) location.

Table 2 – Resistance Requirements for Individual Electrodes

System Type	Number of Grounding Electrodes Tied Together with a Neutral	Maximum Resistance per Grounding Electrode
Considered an Earth Return Neutral	2	6 Ω Winter (4.5 Ω Summer)
	3	12 Ω Winter (9 Ω Summer)
	4	18 Ω Winter (11 Ω Summer)
	5	24 Ω Winter (14 Ω Summer)
Considered a Multi-Grounded Neutral	6 or more	25 Ω Winter (15 Ω Summer)

NOTE: The values of the ‘Maximum Resistance per Grounding Electrode’ found in Table 2 were arrived at by assuming that one of the grounding electrodes does not function as designed.

- d) The maximum overall resistance of a neutral system (MGN or ERN) shall not exceed 6 Ω (4.5 Ω summer). To meet this requirement, the maximum resistances detailed in Table 2 shall be adhered to.
- e) If the earth has very high resistance (rocky, sandy) and 25 Ω (15 Ω summer) cannot practically be attained for individual electrodes, the overall neutral system is still required to be 6 Ω (4.5 Ω summer) or less. Thus, additional electrodes will be required to meet this requirement. The overall resistance for the interconnected neutral system must be calculated using the following formula. Each  $R_n$  value is the meggered resistance of the individual grounding electrodes in ohms (Ω).

$$R_{eq} = \frac{1}{\frac{1}{R_1} + \frac{1}{R_2} + \frac{1}{R_3} + \dots + \frac{1}{R_n}}$$

- f) If the ground grid does not meet the Table 2 requirements, the customers contractor must take remedial action to ensure compliance with Table 2 (the use of deep driven ground rods provide a means of lowering ground resistance in most cases and is recommended)
- g) Test results, showing the date of test, type of equipment and identification used, and measured ground resistances, must be documented as shown below.
- h) The customers contractor must provide a report outlining the ground grid test results prior to final inspection.
- i) The results of these tests must also be added to the “red-line” as-built drawings beside the equipment number or switch number for each piece of equipment identified on the [ground grid test report](#).

- j) The testing authority must sign all test reports, and specify the following information:
- Date of test
  - Equipment identification
  - Ground resistance measured.
- k) After inspection, the remaining excavation can be backfilled and compacted to within  $\pm 150$  mm of final grade.
- l) No backfill will be allowed inside the transformer or cubicle bases.
- m) All conductive aboveground facilities (i.e., metal guard posts or bollards, stand-alone CATV & TELUS pedestals, Third Party facilities, metering pedestals) within 3.0 m of a padmount transformer must be tied into the transformer's ground grid.



#### 7.4. Trench and Duct installation

Duct is always required in the following conditions:

- Within a lease site
- Under pavement, roads, parking lots and driveways
- Where landscaping restricts access to FortisAlberta facilities
- Where soil conditions dictate (example rocky areas with high water table)

Ducting should be installed to a depth of 1.2 m to 1.5 m for road crossings and normal mainline trench should be 1.0 m to 1.2 m from the final ground grade measured from the top of the conduit. Above the duct, 200 mm of sand to be added with red danger electrical tape on top. Any installation from a transformer/switch cubicle to a property line should include a 7 mm pull rope. An above ground marker must be placed at end of the conduit on property line.

Where cable pull tensions exceed 750 lbs., all bends and elbows shall be concrete encased with a minimum of 76 mm (3 inches) throughout the bending radius of the duct. Ducts encased in concrete shall be separated from each other by at least 25 mm of concrete. The concrete mixture shall have a compressive strength of 17.2 MPA (2500 psi).

The minimum duct size for use in primary cable installations shall be 102 mm (4 inches). Only Rigid PVC duct shall be used for elbows (no DB2 is allowed).

90° elbow ducts are to be installed under the equipment (i.e., transformers, pull box, switching cubicles), straight-up, cut-off at 100 mm (4 inches) above the bottom of the base, and install a bell at the end of the duct, where practical. Provisions should be provided to protect the duct upon the installation of the cable when entering/exiting the duct system.

When trenching towards a FortisAlberta asset, maintain the following separations (FortisAlberta will trench the rest of the way):

- Switching Cubicle: 3.0 m
- Riser Pole: 3.0 m
- Edge of utility right-of-way: 1.0 m

Primary duct/cable shall not be placed under buildings.

See [Annex C](#) for further details on conduit systems.

#### 7.5. Guard posts (Bollards)

The requirements for guard posts, including the necessary location and installations, must be confirmed with FortisAlberta prior to construction.

The guard post must be supplied by the customer. Refer to 1302 Bill of Materials.

Guard posts (Bollards) must be installed on all sides of a transformer or cubicle if it is in an area exposed to vehicle traffic and is at the risk of incurring damage from a vehicle. To avoid possible damage to the ground grid the guard posts should be installed before or at the same time as the ground grid. See drawing and materials 1302 for guard post positioning.

Guard posts must be bonded to the ground grid using #4 Cu for single phase or switching cubicles and #2/0 Cu for three phase installations.

If there is a secondary pedestal attached to the equipment/transformer pad, the guard post & ground grid should be extended in such a way as to protect the peripheral equipment also.

Post encasement is to be compacted all around with suitable back fill or gravel.

#### 7.6. Crossing/Proximity to 3<sup>rd</sup> Party Right-Of-Ways, High-Pressure Pipelines and Power Lines

The customer is required to obtain the necessary permissions to enter upon, cross over, or construct under any 3<sup>rd</sup> party right-of-way, high pressure pipelines, power lines, etc. for the installation of the underground electrical facilities. They are also responsible for the preparation and submission of the plans to the owners and/or proper authorities, and for any extra costs, work, damage claims and/or insurance costs related to meeting all conditions for any of the above-mentioned crossings. During the inspection, the customer's consultant shall provide FortisAlberta with one copy of the customer's crossing agreement (i.e., under the customer's name) with the 3<sup>rd</sup> party company (i.e., pipeline, transmission, etc.).

#### 7.7. Crossing/Proximity to Railways

If the customer owns, operates, and maintains the railway, they are responsible for casing a pipe installation under the rails in accordance with all applicable codes, in which case the detailed design and as-built engineer-signed and stamped drawing for the installation under the tracks is still required. If an approval for the installation needs to be obtained from a 3<sup>rd</sup> party (Canadian Pacific or Canadian National Railway Company), FortisAlberta performs the installation under the tracks at the expense of the customer.

**7.8. Easements and Utility Right of Way**

Every facility on customer property that serves two or more customer properties must be protected either by easements or a Utility-Right-of-Way. The necessity for easement and Utility Right of ways will be at the discretion of the FortisAlberta designer.

**7.9. Environmental Considerations**

The customer is required to comply with all federal, provincial, and municipal legislation, regulations, acts and bylaws, as applicable. The following are commonly encountered requirements that may impact the project but is not all inclusive.

The customer may be required to obtain the necessary approvals under Alberta's Water Act or the federal Fisheries Act prior to the installation of the underground electrical facilities. A Water Act approval is required before undertaking a construction activity in a water body or before diverting water from a water body (water bodies include but are not limited to; lakes, ponds, rivers, creeks, seasonal drainages, and wetlands). A Fisheries Act approval is required for any work or activity that results in the harmful alteration, disruption or destruction of fish habitat or permits the deposit of a deleterious substance, one having a harmful effect, into any water frequented by fish. The final reclamation of the excavations impacting a water body must adhere to the conditions in the approval. Deficiencies identified during the final inspection will be rectified by the customer at the customer's expense. During the inspection, the customer or customer's consultant will provide FortisAlberta with one copy of the approval document.

The customer may be required to obtain the necessary clearance under the Alberta Historical Resources Act. A Historical Resources Act clearance is required on identified lands that contain or are believed to contain historic resources, including archaeological and paleontological sites, Aboriginal traditional use sites of a historic resource nature, and historic structures. A list of known Historical Resources is available on the Alberta Culture website. During the inspection, the customer or customer's consultant will provide FortisAlberta with one copy of the approval document.

The customer should also minimize potential adverse effects to wildlife and habitats that may result from the installation of the underground electrical facility. Customers may be required to adhere to the Species at Risk Act or Migratory Birds Convention Act based on the presence of sensitive species or habitats.

**8. Material Standards and Specification****8.1. General requirements**

The customer is responsible for supplying all materials required for meeting the minimum FortisAlberta standards throughout the duration of the work; this includes the customer's delegation to another party to carry out the completion of the work (design consultants, construction contractors, and sub-construction contractors). Furthermore, the customer is responsible for all material supplied, and for the safe storage of all material until it has been incorporated in the completed and accepted work by FortisAlberta. The customer will replace, at no cost to FortisAlberta, any material that has been damaged in transit, or has been damaged after delivery and prior to energization.

All materials used in the design and installation of the underground electrical system will be new and from a manufacturer stated in the accepted list of suppliers provided in 6.2, 6.3 and 6.4 of this publication. If other than accepted materials are incorporated in the work, all such materials will be removed and replaced with accepted materials. This replacement will be completed at the customer's expense, and to the satisfaction of the FortisAlberta field representative, prior to energization.

The accepted suppliers and catalogue numbers listed in the following material sub clauses have been previously evaluated by and/or supplied to FortisAlberta. Any other materials and/or suppliers not listed will not be accepted without prior acceptance from FortisAlberta. Suppliers or manufacturers who want their products to be considered can submit samples and full technical information to FortisAlberta for evaluation.

## 8.2. Pre-Cast Concrete

Pre-cast concrete bases are used for mounting single and three phase pad-mount transformers, solid dielectric switchgear, and live front switching cubicles as shown in Table 3. Drawings of the bases are provided with the corresponding links in Table 3.

Table 3 – Bases and Guard Posts

Description	Approved Suppliers	FortisAlberta Drawing No.
<b>Pre-cast Concrete Base for Single Phase Transformer up to 167 kVA</b>	D&M Concrete Eagle Builders H.O. Concrete Knelsen Precast LaFarge Pretech	<u>755-0505</u>
<b>Pre-cast Concrete Base for Three Phase Transformer from 75 kVA and up to 500 kVA</b>	D&M Concrete Eagle Builders Knelsen Precast LaFarge Proform Concrete Westcon Precast	<u>755-0507</u>
<b>Pre-Cast Concrete Base for Three Phase Transformer from 750 kVA and up to 3000 kVA</b>	D&M Concrete Eagle Builders Knelsen Precast LaFarge Westcon Precast	<u>755-0512</u>
<b>Pre-Cast Concrete Base for Three Phase Transformer from 1000 kVA and up to 20000 kVA</b>	Lafarge	<u>755-0516</u>
<b>Pre-Cast Concrete Base for Three Phase 2-Way Padmount MVI</b>	Proform	<u>755-0570</u>
<b>Pre-Cast Concrete Base for Three Phase 4-Way Padmount MVI and Three Phase Switching Cubicle</b>	Knelsen Precast LaFarge	<u>755-0557</u>
<b>Guard Post and base with grounding stud</b>	Knelsen Precast LaFarge	<u>1302</u>

8.3. Grounding Materials

The materials that can be used when installing the grounding and ground grids around padmount transformers, switching cubicles, secondary junction boxes and pedestals, streetlights, and pull boxes can be found in Section 15.5 of the FortisAlberta’s Service and Metering Guide as presented in [Annex E](#).

8.4. Conduit Materials

The materials that can be used when installing the conduit (ducts) can be found in Section 15.4 of the FortisAlberta’s Service and Metering Guide as presented in [Annex D](#).

8.5. Guard Post Materials



The guard posts (bollards) in Table 3 are built to protect the transformer. They must be built and positioned according to the material in Table 3 and as shown in the (1302) drawings.

## **9. Inspection and Testing**

### **9.1. General Requirements**

FortisAlberta will have the final say regarding any installation/construction issues, discrepancies, and/or problems. An inspection will take place after the customer completes their installation, and before any backfilling takes place.

### **9.2. Scheduling Inspections**

The customer is to call 310-WIRE (9473) five (5) working days prior to the backfill of any underground facilities. FortisAlberta field representatives work eight (8) hour days between the hours of 7:30 a.m. through 4:00 p.m. (including travel time to site), Monday through Friday. It is the contractor's responsibility to coordinate all inspections accordingly. Any requests outside these hours will be at the discretion of the FortisAlberta field representative and at the contractor's cost. All notifications after 4:00 p.m. on any given working day will be considered as occurring the next business day.

If the customer proceeds without inspection prior to backfilling, they will be responsible for any additional cost and/or delays incurred to rectify any problems that may develop (e.g., hydrovac costs).

### **9.3. Warranty**

The customer must provide an eighteen-month warranty on all facilities, including any that may be leaning or not to grade due to improper installation or tampering. This warranty should be effective following the service energization.

If there are any deficiencies during the warranty period, the customer shall remedy the deficiency, commence a remedy on the deficiency, or come to an agreement with FortisAlberta on the remedial action necessary within thirty (30) days of notice from FortisAlberta.

**Annex A Revision History (Informative)**

Version	Comments	Date
1	Initial	2009
2	Added Switch Cubicle and MVI base. Concrete poured in bends.	May-13
3	Added Environmental Considerations.	Aug-15
	Added base for larger transformers 755-0514.	
	Revised 1302 drawings.	
4	Site grading requirements added.	Oct-15
	Moved the warranty information to 7.3.	
	Depth of concrete required on elbows 5.3.	
	No electrical cables under buildings 5.3.	
	Foundation support requirement 5.1.	
	Bill of Material, changes to pad based on voltage as well as capacity (MVA), 6.2. Annex A Bill of Material.	
4.1	New complex AFC example in annex.	Mar-16
	2.4 and annex: application for before curb and gutter installations.	
	How-to brochure as annex.	
	2.6 clarification to grading requirements	
	7.3 warranty clarification	
4.2	2.4 cable pulling clarification	Sep-16
4.3	General & Applicability section clarification	Aug-18
	5.1 Clarification on minimum separation requirements	
	5.3 Updates on duct requirements	
	Other minor changes for clarification	
4.4	Section 6.2 Changed supplier name from Armttec to Knelsen. 755-0514 discontinued and removed	Oct-19
5.0	General rearrangement and formatting. New cover page.	Nov-20
	Section 1.1, added texts to follow CIPGD process for efficient installation of facilities.	
	Section 4, added “off-site work” and “UEDS” in the glossary.	
	Section 6.3, added text regarding ground testing.	
	Section 7.4 added stipulation to concrete encase sweeps and elbows where pulling tension exceeds 750 lbs. Added reference to Annex C of the SMG for detail on Duct Systems	
	Section 8.2 changed the description from Molded Vacuum Switch (MVI) to Solid Dielectric Switch also modified the description for switching cubicles	

Version	Comments	Date
	stating that they are live front switching cubicles. Change Table number from 2 to 3 and any reference to it in this section. Updated manufacture information added Wescon Precast to item 755-0507 and 755-0512. Added a new item no. 755-0516 to replace 755-0514.	
	Section 8.3 and 8.4, provided references to SMG sections and provided in Annex D and E.	
	Annex A, Version History Updated	
	Annex B replaced 755-0514 with 755-0516; modified Annex to Forms and References; all references are now in Word format. Removed "How-to-Guide" reference document. Added Structure 1226.	
	Annex C, included SMG, Annex C, Conduit Systems	
	Annex D, included SMG, Section 15.4, Conduit materials	
	Annex E, included SMG, Section 15.5, Grounding Materials	
5.1	Included 1226 (2/3) and 1315 (2/4) Structure Drawings in Annex B.	Dec-22
	Expanded Table 1 with additional details.	
5.2	Provided clarity on when to pour concrete on bends and elbows. Updated AFC prints and checklists.	Aug-23
	Updated Annex D, Conduit materials	

**Annex B Forms and Reference (Informative)**

1. Structure Drawing 1302 (2 pages and Bill of Materials), Service Guard Post
2. SMG 7.1, Commercial Services, Location of Padmount Transformers
3. Structure Drawing 1315, Three Phase Padmount Transformer General Arrangement
4. Structure 1515, Three Phase Transformer, Civil and Grounding Bill of Materials
5. Structure Drawing 1226, Single Phase Pad Mount Transformer, General Arrangement
6. Structure 1526, Single Phase Transformer, Civil and Grounding Bill of Materials
7. Drawing 755-0505, Pre-Cast Concrete Base for 1-Phase Transformer up to 167 kVA
8. Drawing 755-0507, Pre-Cast Concrete Base for 3-Phase Transformer up to 500 kVA
9. Drawing 755-0512, Pre-Cast Concrete Base for 3-Phase Transformer, 750 to 3000 kVA
10. Drawing 755-0516, Pre-Cast Concrete Base for 3-Phase Transformer, 1000 to 20000 kVA
11. Drawing 755-0557, Pre-Cast Concrete Base for 3-Phase, Switching Cubicle & 4-Way MVI
12. Drawing 755-0570, Pre-Cast Concrete Base for 3-Phase, 2-Way MVI
13. CIPGD Process Flowchart
14. Ground Grid Test Report
15. Example and Template of AFC for Simple Services
16. Example of AFC for Complex Services
17. Application to Install Underground Electrical Distribution Systems Without Curbs and Gutters

1. Structure Drawing 1302 (2 pages and Bill of Materials), Service Guard Post

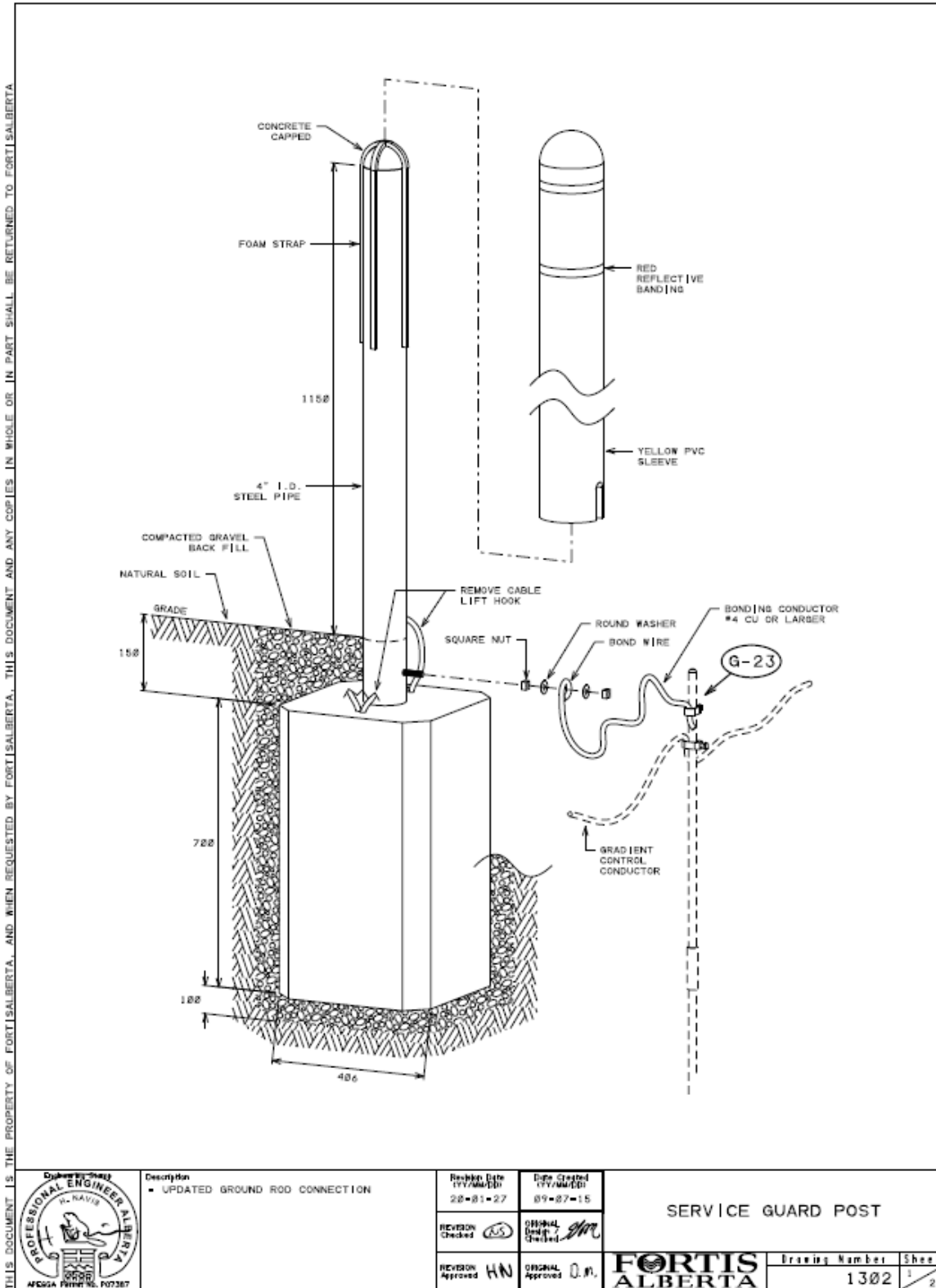

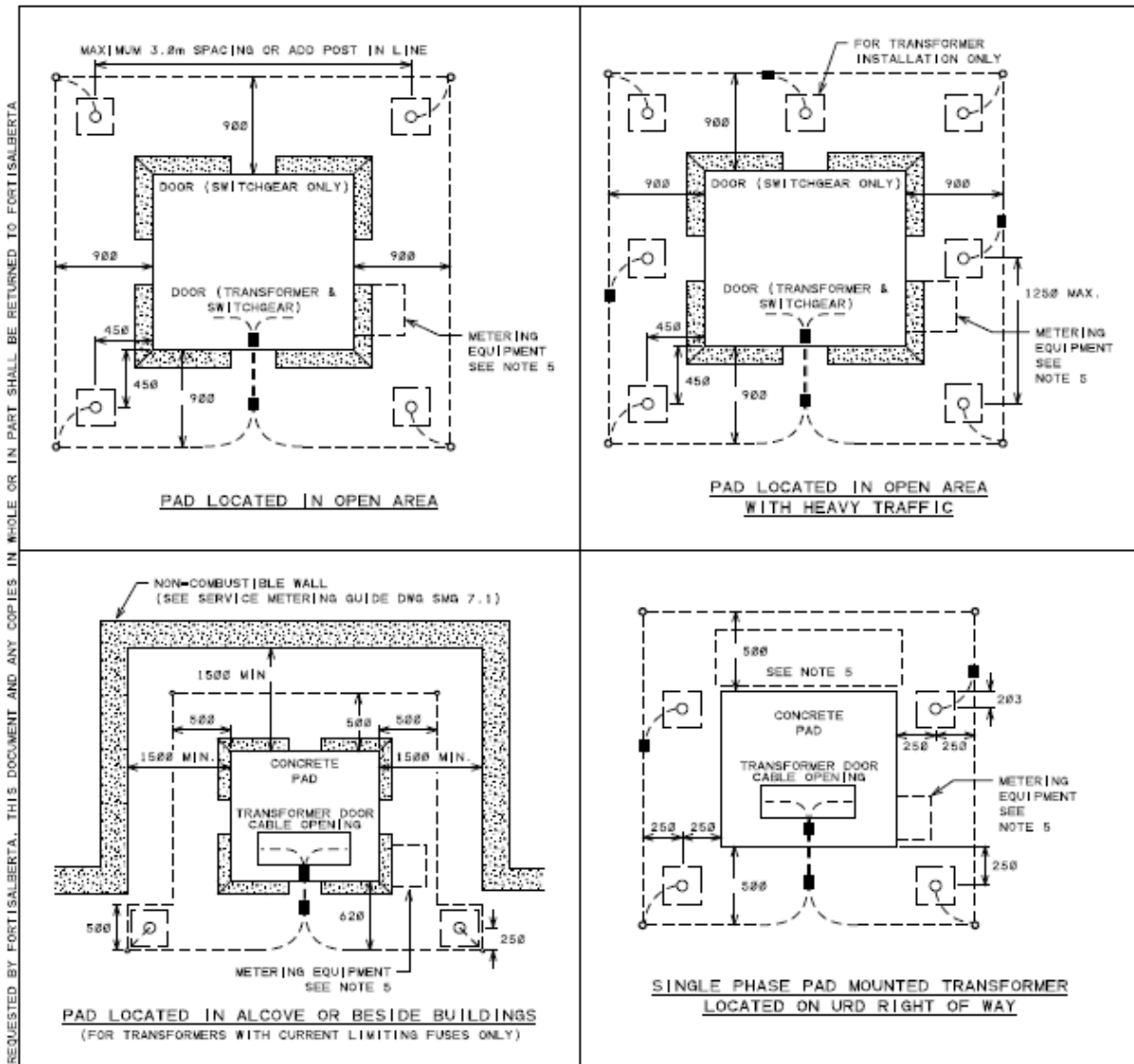

THIS DOCUMENT IS THE PROPERTY OF FORTISALBERTA, AND WHEN REQUESTED BY FORTISALBERTA, THIS DOCUMENT AND ANY COPIES IN WHOLE OR IN PART SHALL BE RETURNED TO FORTISALBERTA.

**NOTE:**

- 1 - WHERE THE TRANSFORMER IS LOCATED IN AN AREA EXPOSED TO VEHICLE DAMAGE, THE GUARD POSTS MUST BE SUPPLIED BY THE CUSTOMER
- 2 - AS MEASURED FROM THE EDGE OF THE CONCRETE SWITCHGEAR/ TRANSFORMER PAD, THERE SHALL BE A MINIMUM OF 4M WORKING SPACE CLEARANCE ON THE SWITCHGEAR/ TRANSFORMER DOOR SIDE AND A MINIMUM OF 1.5M ON ALL OTHER SIDES
- 3 - FOR GROUND GRID DETAILS, SEE DRAWING 1226 FOR SINGLE PHASE OR 1315 FOR THREE PHASE TRANSFORMER APPLICATIONS FOR GROUND GRID DETAILS, SEE DRAWING 1593 FOR PAD MOUNT SWITCH APPLICATIONS
- 4 - THE REQUIREMENTS FOR GUARD POSTS, INCLUDING THE NECESSITY LOCATION AND INSTALLATION MUST BE CONFIRMED WITH FORTISALBERTA PRIOR TO CONSTRUCTION
- 5 - IF THERE IS A SECONDARY PEDESTAL/ METERING EQUIPMENT ATTACHED TO THE SWITCHGEAR/TRANSFORMER PAD, THE GUARD POST & GROUND GRID SHOULD BE EXTENDED IN SUCH A WAY TO PROTECT THE PERIPHERAL EQUIPMENT ALSO
- 6 - POST ENCASUREMENT TO BE COMPACTED ALL AROUND WITH SUITABLE BACK FILL OR GRAVEL
- 7 - UNLESS OTHERWISE INDICATED, ALL DIMENSIONS ARE IN MILLIMETRES



**Description:**

- RELOCATED THE TAIL BAND CONNECTION OF THE GRID AS IT ENTERS THE VAULT SUCH THAT IT IS CLEAR THAT THERE IS A CONNECTION INSIDE OF THE VAULT
- UPDATED SERVICE AND METERING GUIDE LOOKUP
- REVISED NOTE 2 CLEARANCE CHANGED FROM 3M TO 4M

Revision Date 16-09-13	Date Created 09-07-15
Revision Checked <i>MS</i>	Original Design Checked <i>MM</i>
Revision Approved <b>HN</b>	Original Approved <b>C.P.</b>

**SERVICE GUARD POST**

<b>FORTIS ALBERTA</b>	Drawing Number 1302	Sheet 2 / 2
-----------------------	------------------------	----------------

Structure #: 1302		FortisAlberta 2020/06/09							Page: 1			
Description: SERVICE GUARD POST												
Item #	Description	UI	-1	-	-	-	-	-	-	-	-	-
5141104	NUT, SQUARE, 1/2 INCH, UNC 13, GALV		2									
5142102	WASHER, ROUND, 9/16" HOLE, 1-3/8" RIM		2									
5150802	POST, BUMPER, HEAVY DUTY		1									
5310220	CONDUCTOR, STR, #4, CU.	M	1									
5571311	CONNECTOR, FOR 5/8" TO 3/4" GND. ROD		1									

REMARKS:

Bill of material is for one guard post only, order additional guard posts where required.

2. SMG 7.1, Commercial Services, Location of Padmount Transformers

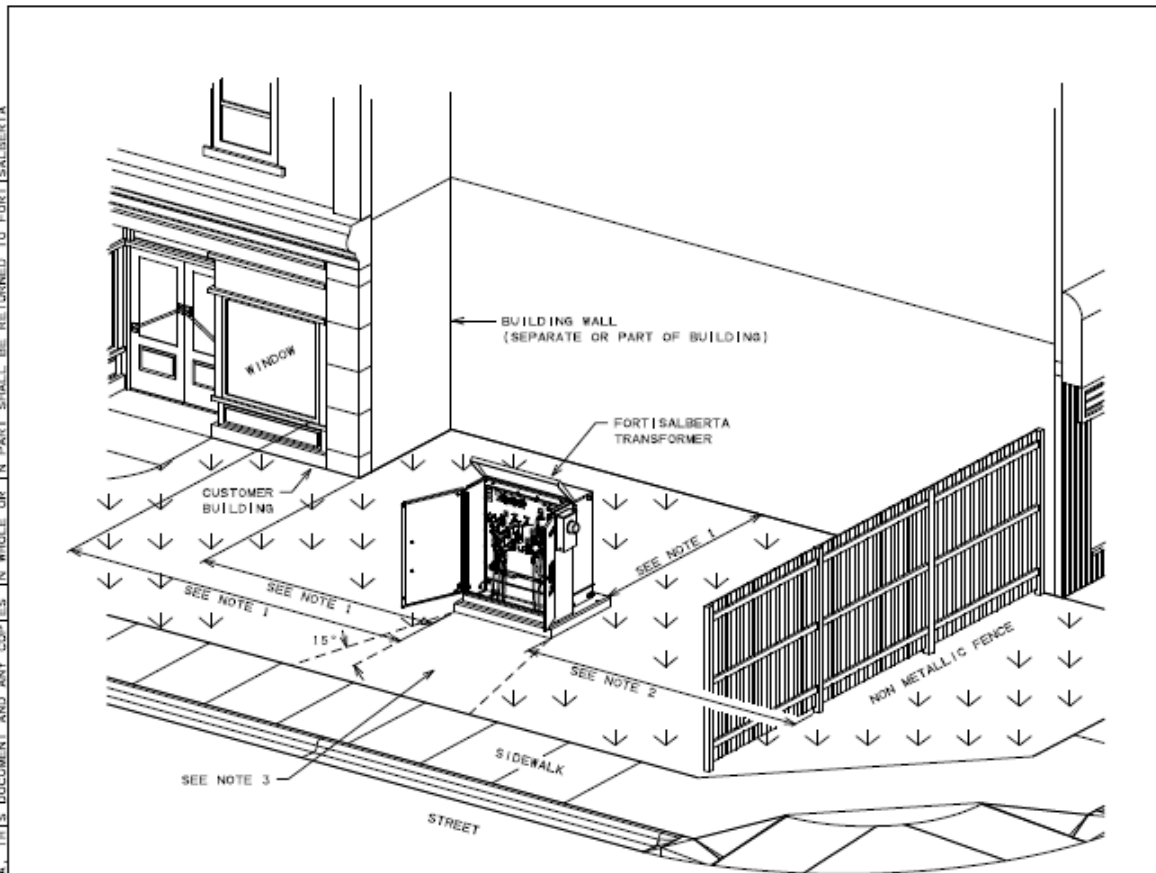

NOTE:

- 1. FOR ALL SINGLE PHASE AND THREE PHASE TRANSFORMERS LESS THAN OR EQUAL TO 3MVA (WITH CURRENT LIMITING FUSING):
  - AS MEASURED FROM THE DECK EDGE OF THE CONCRETE PAD, THERE SHALL BE A MINIMUM OF 4.0m WORKING SPACE CLEARANCE ON THE TRANSFORMER DOOR SIDE AND A MINIMUM OF 1.5m (FOR OPERATIONAL REASONS), ON ALL OTHER SIDES
- FOR ALL THREE PHASE TRANSFORMERS 4MVA AND ABOVE (WITHOUT CURRENT LIMITING FUSING):
  - AS MEASURED FROM THE DECK EDGE OF THE CONCRETE PAD, THERE SHALL BE A MINIMUM OF 4.0m WORKING SPACE CLEARANCE ON THE TRANSFORMER DOOR SIDE AND AT LEAST 4.0m FROM ANY COMBUSTIBLE SURFACE OR MATERIAL ON A BUILDING AND AT LEAST 6.0m FROM ANY WINDOW, DOOR, OR VENTILATION INLET OR OUTLET ON A BUILDING, EXCEPT WHERE A WALL OR BARRIER WITH NON-COMBUSTIBLE SURFACES, OR MATERIAL (AS PER CAN/ULC-S114) IS CONSTRUCTED BETWEEN THE TRANSFORMER AND ANY DOOR, WINDOW, VENTILATION OPENING, OR COMBUSTIBLE SURFACE.
  - IF A BARRIER USING A NON-COMBUSTIBLE SURFACE IS TO BE USED (BLAST WALL) MINIMUM DISTANCE TO THE TRANSFORMER PAD SHALL BE 1.5m
- 2. ADDITIONAL CLEARANCE MAY BE REQUIRED BETWEEN METALLIC OBJECTS (SUCH AS A FENCE) AND THE TRANSFORMER TO REDUCE SAFETY HAZARDS (STEP AND TOUCH POTENTIAL). IF METALLIC OBJECTS ARE REQUIRED CLOSER THAN 5M TO THE TRANSFORMER UNIT, THE UTILITY SHALL BE ALERTED AND THE HAZARD SHALL BE ASSESSED
- 3. THE GRADE MUST BE LESS THAN 9.5° (1:6 GRADE) FOR THE 4m CLEAR AREA IN FRONT OF THE TRANSFORMER
- 4. THE TOP OF THE TRANSFORMER MUST NOT BE BLOCKED OR COVERED
- 5. THE AREA IMMEDIATELY IN FRONT OF THE TRANSFORMER MUST BE KEPT FREE OF ALL OBSTRUCTIONS
- 6. UNLESS OTHERWISE INDICATED, ALL DIMENSIONS ARE IN MILLIMETRES

THIS DOCUMENT IS THE PROPERTY OF FORTISALBERTA, AND WHEN REQUESTED BY FORTISALBERTA, THIS DOCUMENT AND ANY COPIES IN WHOLE OR IN PART SHALL BE RETURNED TO FORTISALBERTA

<p><b>NO STAMP NEEDED</b></p>	<p>Engineering Stamp</p>	<p>Description</p> <ul style="list-style-type: none"> <li>- REVISED NOTE 1 FROM 3M TO 4M FROM A COMBUSTIBLE WALL</li> <li>- REVISED NOTES TO PROVIDE INFORMATION REGARDING CLEARANCES FROM A METALLIC FENCE</li> <li>- UPDATED TRANSFORMER PAD DRAWING</li> </ul>	<p>Revision Date (YY/MM/DD)</p> <p>18-02-22</p>	<p>Date Created (YY/MM/DD)</p> <p>07-07-15</p>	<p><b>COMMERCIAL SERVICES</b></p> <p><b>LOCATION OF</b></p> <p><b>PADMOUNT TRANSFORMERS</b></p>	
			<p>REVISION Checked</p> <p><i>[Signature]</i></p>	<p>ORIGINAL Design / Checked</p> <p><i>[Signature]</i></p>		
			<p>REVISION Approved</p> <p><b>HN</b></p>	<p>ORIGINAL Approved</p> <p><i>[Signature]</i></p>		
			<p><b>FORTIS ALBERTA</b></p>		<p>Drawing Number</p> <p>SMG 7.1</p>	<p>Sheet</p> <p>1 / 1</p>



3. Structure Drawing 1315, Three Phase Padmount Transformer General Arrangement

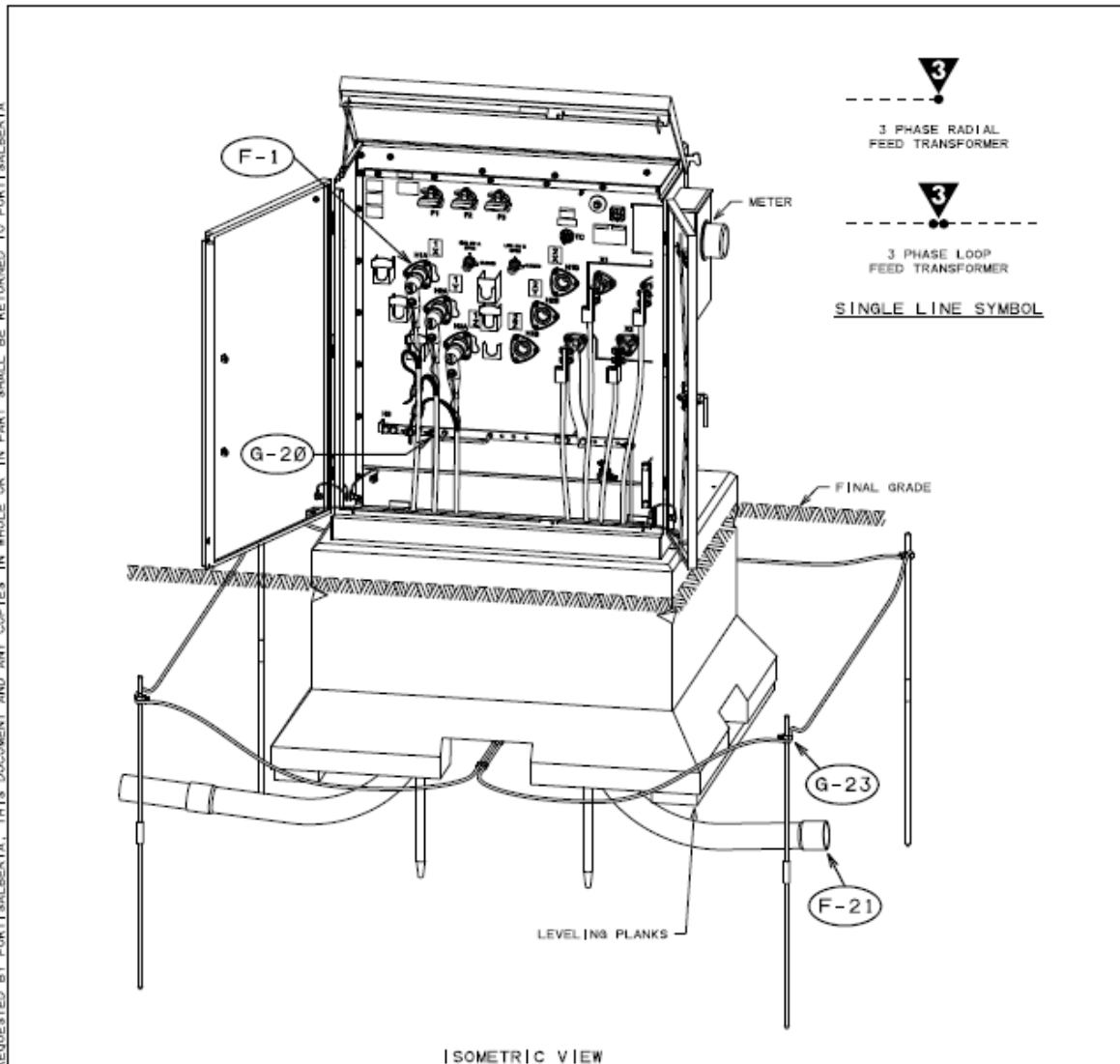

ISOMETRIC VIEW

NOTE:

- 1 - FOR INSTALLATION OF ELBOW TERMINATOR, SEE DISTRIBUTION CONSTRUCTION AND OPERATIONS STANDARDS 536-02
- 2 - DE-ENERGISE TRANSFORMER BEFORE DISCONNECTING GROUND AT XØ
- 3 - EQUIPMENT PADS ARE NOT TO BE PLACED ON SOILS THAT ARE IN CLASS 7 SOIL (WET, PEAT, ORGANICS) WITHOUT SPECIAL FOUNDATIONS BEING REQUIRED
- 4 - WHERE METALLIC GUARD POSTS, RAILS, OR SIMILAR BARRIERS ARE USED (FOR GUARD POST DIMENSIONS SEE DWG 1302) TO PROVIDE MECHANICAL PROTECTION FOR PADMOUNTED EQUIPMENT, GRADIENT CONTROL PROTECTION SHALL BE PROVIDED TO MAINTAIN SAFE TOUCH AND STEP POTENTIALS AS REQUIRED
- 5 - LEAVE 2m OF EACH CONDUCTOR TAIL FOR CONNECTION TO EQUIPMENT CASE
- 6 - UNLESS OTHERWISE INDICATED, ALL DIMENSIONS ARE IN MILLIMETRES

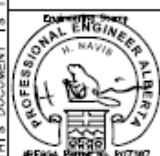

Description:  
 - UPDATED GROUNDS  
 - ADDED WOOD PLANKS UNDER BASE

Revision Date (YY/MM/DD): 23-01-27  
 Date Created (YY/MM/DD): 22-06-10

REVISION Checked: *AS* Original Design / Checked: *AS*

REVISION Approved: *HN* ORIGINAL Approved: *AS*

**THREE PHASE  
PADMOUNT TRANSFORMER  
GENERAL ARRANGEMENT**



Drawing Number	Sheet
1315	1 / 4

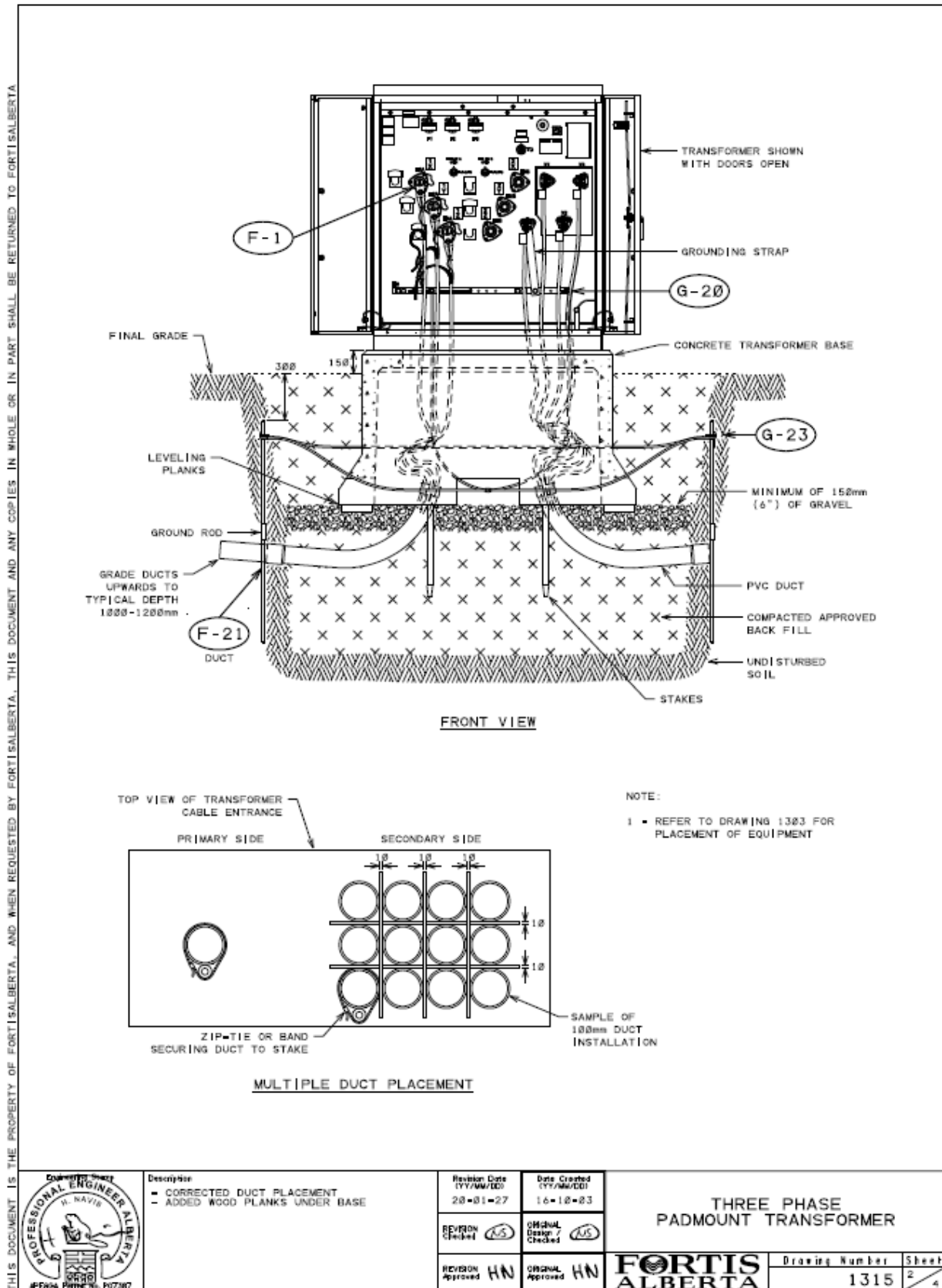

THIS DOCUMENT IS THE PROPERTY OF FORTISALBERTA, AND WHEN REQUESTED BY FORTISALBERTA, THIS DOCUMENT AND ANY COPIES IN WHOLE OR IN PART SHALL BE RETURNED TO FORTISALBERTA.

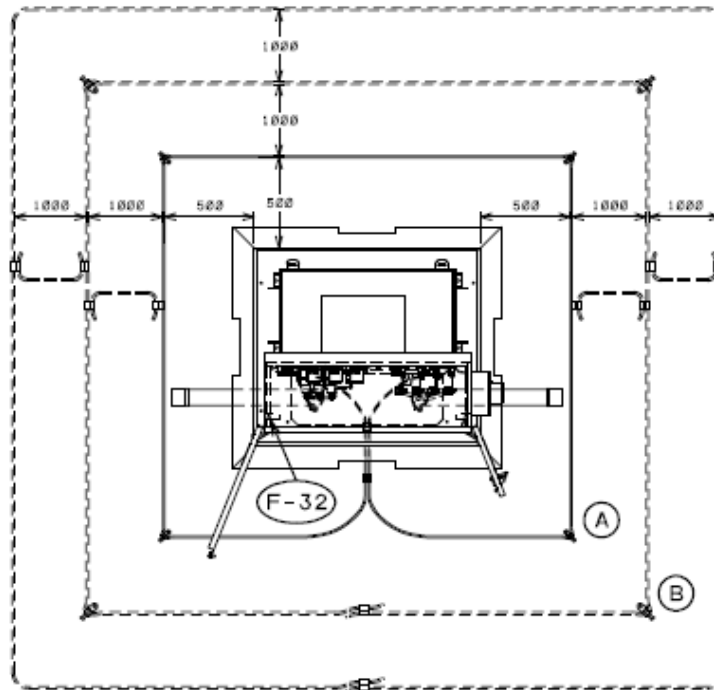

(A) - SEE NOTE 1      (B) - SEE NOTE 2

**PLAN VIEW**

**NOTE:**

- 1 - GROUNDING REQUIREMENT (GRADIENT CONTROL) FOR THREE PHASE EQUIPMENT WITH A MULTI-GROUNDED NEUTRAL
- 2 - IF A MULTI-GROUNDED NEUTRAL SYSTEM IS NOT PRESENT INSTALL ADDITIONAL GRADIENT CONTROL CONDUCTOR BY RELOCATING THE GROUND RODS TO 1500mm FROM THE EQUIPMENT PAD AND INSTALLING AN ADDITIONAL TWO GRADIENT CONTROL LOOPS AROUND THE EQUIPMENT (FOR A TOTAL OF 3 LOOPS) AS SHOWN
- 3 - CABLE MAY BE IN DUCT UNDER BOX PAD
- 4 - NUMBER OF DUCTS IS LIMITED BY THE SIZE OF THE OPENING TO THE SECONDARY COMPARTMENT OF A TRANSFORMER. 50mm, 75mm, 100mm, AND 150mm DUCTS MAY BE INSTALLED. WHEN FORTISALBERTA INSTALLS A TRANSFORMER, EITHER 100mm OR 150mm DUCTS WILL BE INSTALLED
- 5 - CABLE LARGER THAN 75MCM MUST BE APPROVED BY FORTISALBERTA
- 6 - ALL SECONDARY CONNECTOR LUGS SHALL BE SUPPLIED BY CUSTOMER. LUGS SHALL BE ONE HOLE MECHANICAL, AL/CU LUG, FITTED FOR TRANSFORMER PAD AND CABLE SIZE BUT NOT LARGER THAN 40mm IN WIDTH
- 7 - NUMBER OF CABLES IS LIMITED TO 6 PER PHASE
- 8 - IF ARMoured CABLE IS USED, ARMoured JACKET MUST BE STRIPPED DOWN TO DUCT
- 9 - LUGS CONNECTION TO TRANSFORMER SECONDARY PAD SHALL BE MADE TO THE TERMINALS MARKED X<sub>1</sub>, X<sub>2</sub>, & X<sub>3</sub>. NEUTRAL LUGS SHALL BE CONNECTED TO THE TERMINAL MARKED X<sub>0</sub>
- 10 - UNLESS OTHERWISE INDICATED, ALL DIMENSIONS ARE IN MILLIMETRES (INCHES)

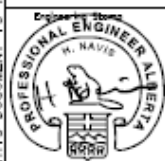

Description	Revision Date 11/14/03	Date Created 16-10-03
	REVISION Checked	ORIGINAL Design / Checked
	REVISION Approved	ORIGINAL Approved

Revision Date 11/14/03	Date Created 16-10-03
REVISION Checked	ORIGINAL Design / Checked
REVISION Approved	ORIGINAL Approved

<b>THREE PHASE PADMOUNT TRANSFORMER</b>	
<b>FORTIS ALBERTA</b>	Drawing Number    Sheet 1315                    3 / 4

**4. Structure 1515, Three Phase Transformer, Civil and Grounding Bill of Materials**

Structure #: 1515		FortisAlberta		2020/02/13		Page: 1						
Description: CIVIL AND GND METHOD, 3- PH TRANSFORMER												
Item #	Description	UI	-1	-2	-3	-4	-5	-6	-	-	-	-
5310202	WIRE, COPPER, STR, SD BARE, 2/0	M	17	81	20	81	22	81				
5530155	CONNECTOR, PARALLEL GROOVE, 1 TO 2/0		2	13	2	13	2	13				
5571311	CONNECTOR, FOR 5/8" TO 3/4" GND. ROD		4	4	4	4	4	4				
5571421	ROD, GRD, SECT, 3/4 X 4' CU-CLAD TAPERED		16	16	16	16	16	16				
5571525	COMPRES. COUPLING, SECT. CU-CLAD GRD ROD		12	12	12	12	12	12				
7550507	PAD, PRECAST CONCRETE, TRANS, 75-500KVA		1	1								
7550512	PAD, PRECAST CONCRETE, TRANS, 750-3000KVA				1	1						
7550516	PAD, PRECAST CONCRETE, TRANS, 1-20 MVA						1	1				

**REMARKS:**

- Structure 1515 is for customer installed pad and grounds.
- 1515-1 is for all three phase pad mounted transformers 75-500kVA with a multi-grounded neutral; see structure drawing 1315 (BOM ref. 1315-1) for grounding detail.
- 1515-2 is for all three phase pad mounted transformers 75-500kVA without a multi-grounded neutral; see structure drawing 1315 (BOM ref. 1315-2) for grounding detail.
- 1515-3 is for all three phase pad mounted transformers 750-3000kVA with a multi-grounded neutral; see structure drawing 1315 (BOM ref. 1315-4) for grounding detail.
- 1515-4 is for all three phase pad mounted transformers 750-3000kVA without a multi-grounded neutral; see structure drawing 1315 (BOM ref. 1315-5) for grounding detail.
- 1515-5 is for three phase pad mounted transformers 1000-5000kVA, 4.16kV secondary and 4000kVA, 600V secondary with a multi-grounded neutral; see structure drawing 1315 (BOM ref. 1315-6) for grounding detail.
- 1515-6 is for three phase pad mounted transformers 1000-5000kVA, 4.16kV secondary and 4000kVA, 600V secondary without a multi-grounded neutral; see structure drawing 1315 (BOM ref. 1315-7) for grounding detail.
- When required for leveling of the pre-cast base, order (2) 2" x 8" x 12' leveling planks item 503-0602.
- Coil excessive grounding conductor and leave in vault.
- For temporary lid cover for structures 1515-1 and 1515-2 order:
  - 755-0606 1081mm x 481mm lid
  - 513-2501 5/8 inch hex bolt
  - 514-3000 5/8 inch flat washer
  - 514-3001 5/8 inch lock washer

5. Structure Drawing 1226, Single Phase Pad Mount Transformer, General Arrangement

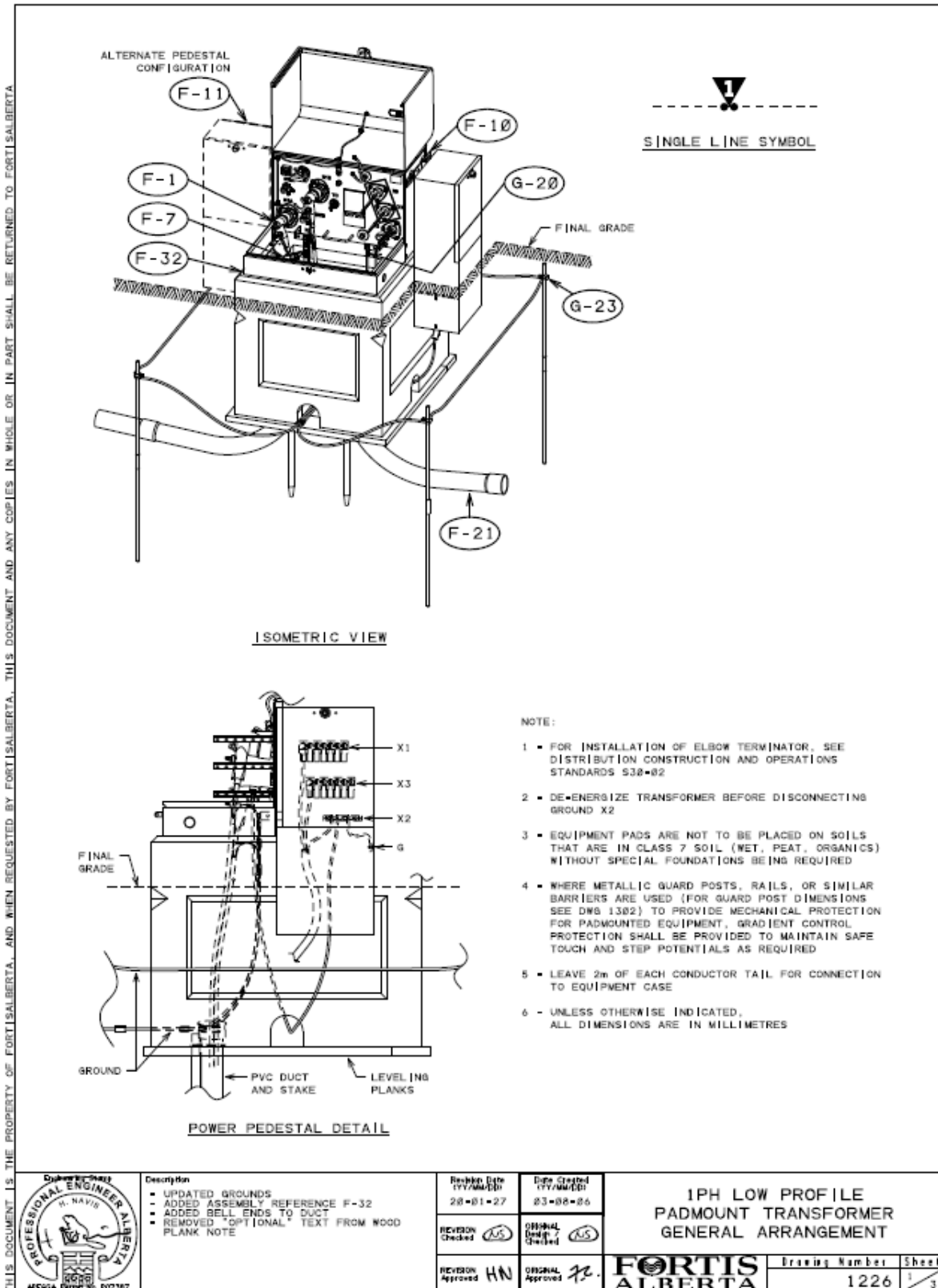

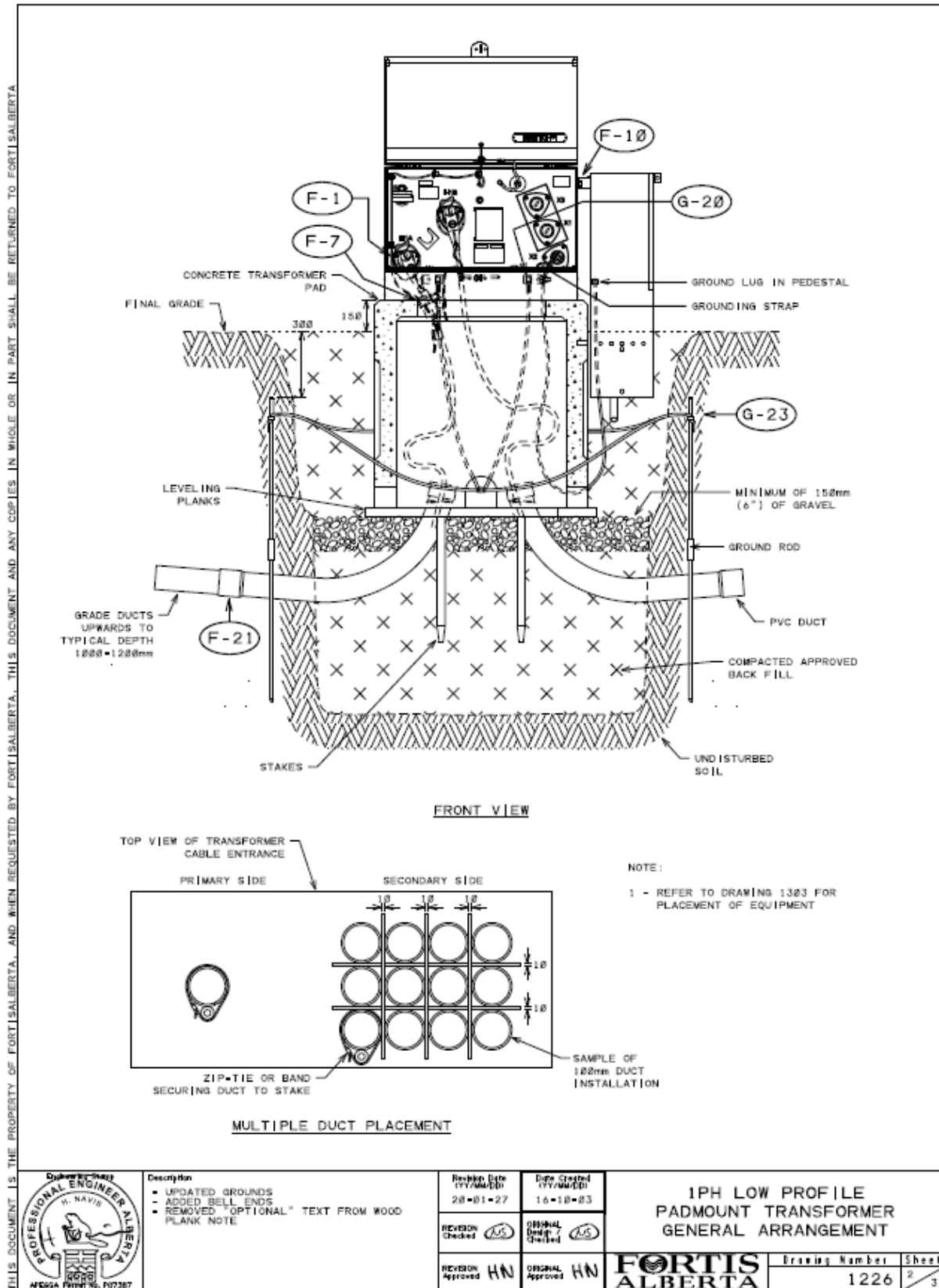

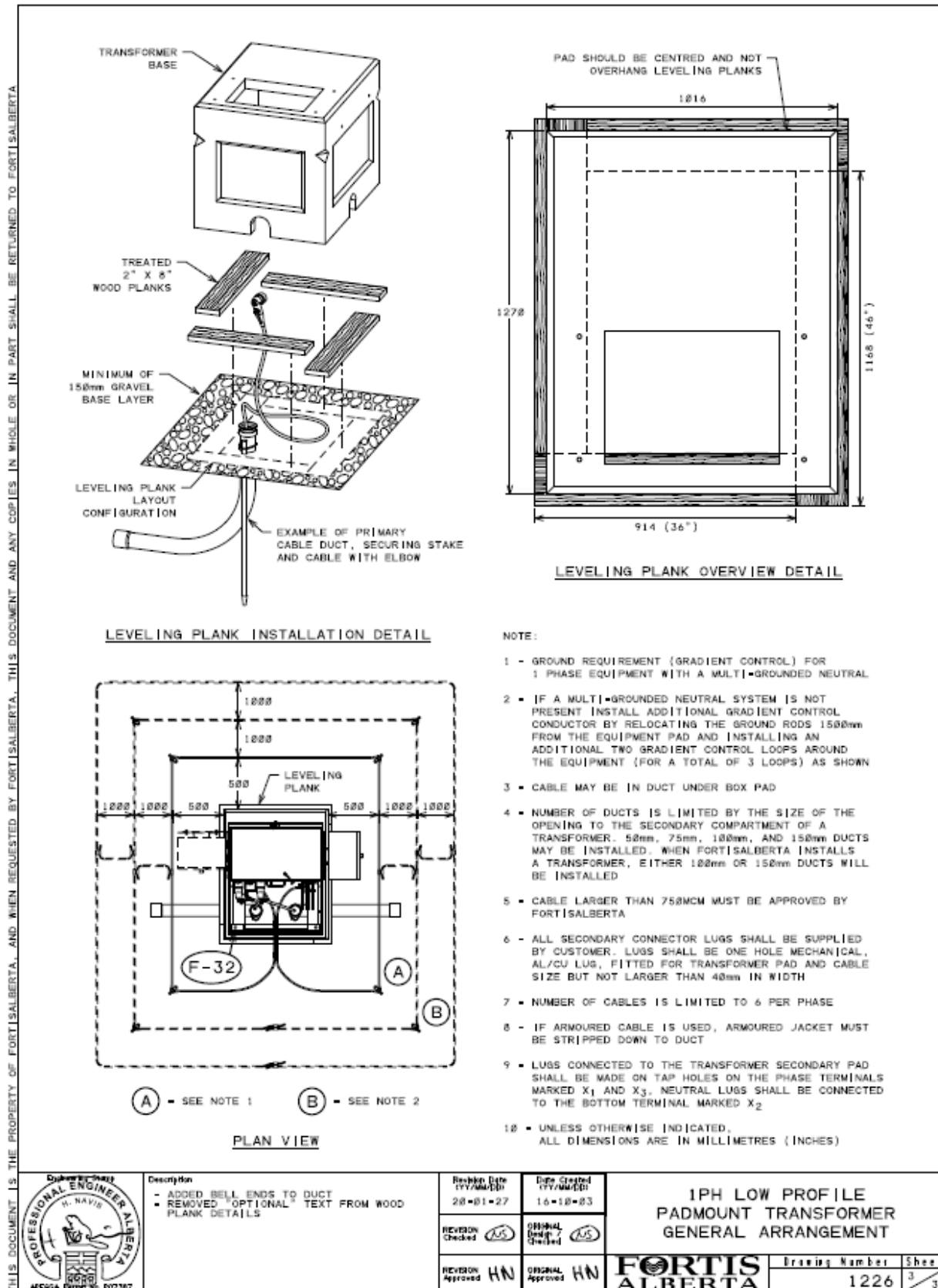

<b>Description</b> - ADDED BELL ENDS TO DUCT - REMOVED "OPTIONAL" TEXT FROM WOOD PLANK DETAILS	Revision Date 28-01-27	Date Created 16-10-23	
	REVISION Checked JUS	ORIGINAL Design Checked JUS	
	REVISION Approved HN	ORIGINAL Approved HN	

<b>1PH LOW PROFILE PADMOUNT TRANSFORMER GENERAL ARRANGEMENT</b>	
<b>FORTIS ALBERTA</b>	Drawing Number 1226
Sheet 3	3

**6. Structure 1526, Single Phase Transformer, Civil and Grounding Bill of Materials**

Structure #: 1526		FortisAlberta		2021/05/07		Page: 1					
Description: CIVIL AND GND METHOD, 1- PH TRANSFORMER											
Item #	Description	UI	-1	-	-	-	-	-	-	-	-
5030603	LUMBER, 2" X 8" X 12 FT, FIR, TREATED		2								
5310220	CONDUCTOR, STR, #4, CU.	M	25								
5530152	CONNECTOR, COMP PG, CU, U/G NEUT		2								
5571311	CONNECTOR, FOR 5/8" TO 3/4" GND. ROD		4								
5571421	ROD, GRD, SECT, 3/4 X 4' CU-CLAD TAPERED		8								
5571525	COMPRES. COUPLING, SECT. CU-CLAD GRD ROD		4								
7550505	BASE, PRECAST FOR MINI:PAD TRANSFORMER		1								

May 7, 2021. Replce 503-0602 with 503-0603.

REMARKS:

- 1526-1 is for all single phase padmounted transformer and switching cubical installations with a multi-grounded neutral system; see structure drawing 1226 and 1230 (BOM ref. 1226-8 and 1230-3) for the grounding detail.
- 1526-2 is for all single phase padmounted transformer and switching cubical installations where a multi-grounded neutral system is not preset; see structure drawing 1226 and 1230 (BOM ref. 1226-8 and 1230-3) for the grounding detail.
- Coil excessive grounding conductor and leave in vault.
- For temporary lid cover for order:
  - 755-0605 890mm x 530mm lid
  - 513-2501 5/8 inch hex bolt
  - 514-3000 5/8 inch flat washer
  - 514-3001 5/8 inch lock washer



7. Drawing 755-0505, Pre-Cast Concrete Base for 1-Phase Transformer up to 167 kVA

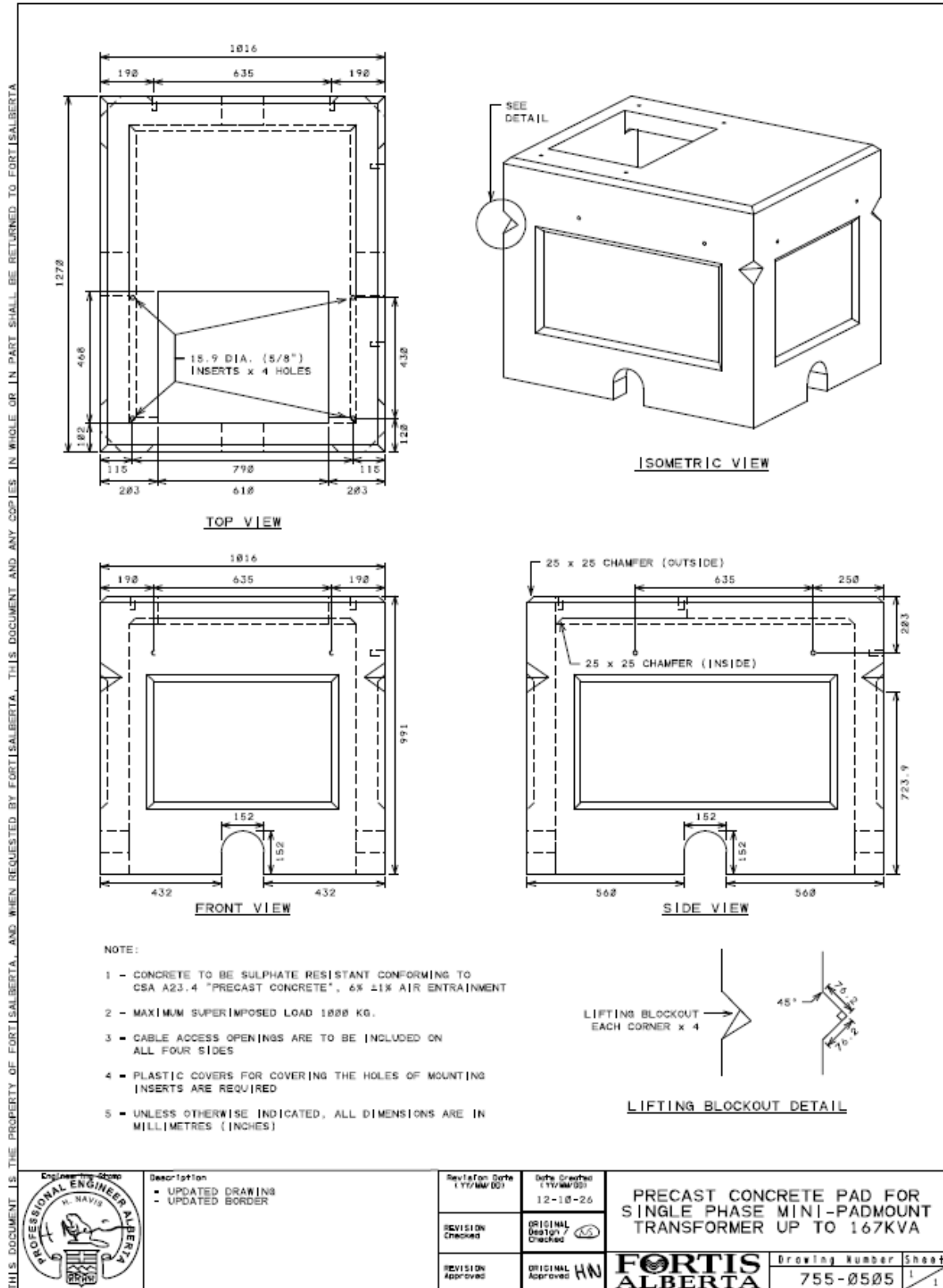

8. Drawing 755-0507, Pre-Cast Concrete Base for 3-Phase Transformer up to 500 kVA

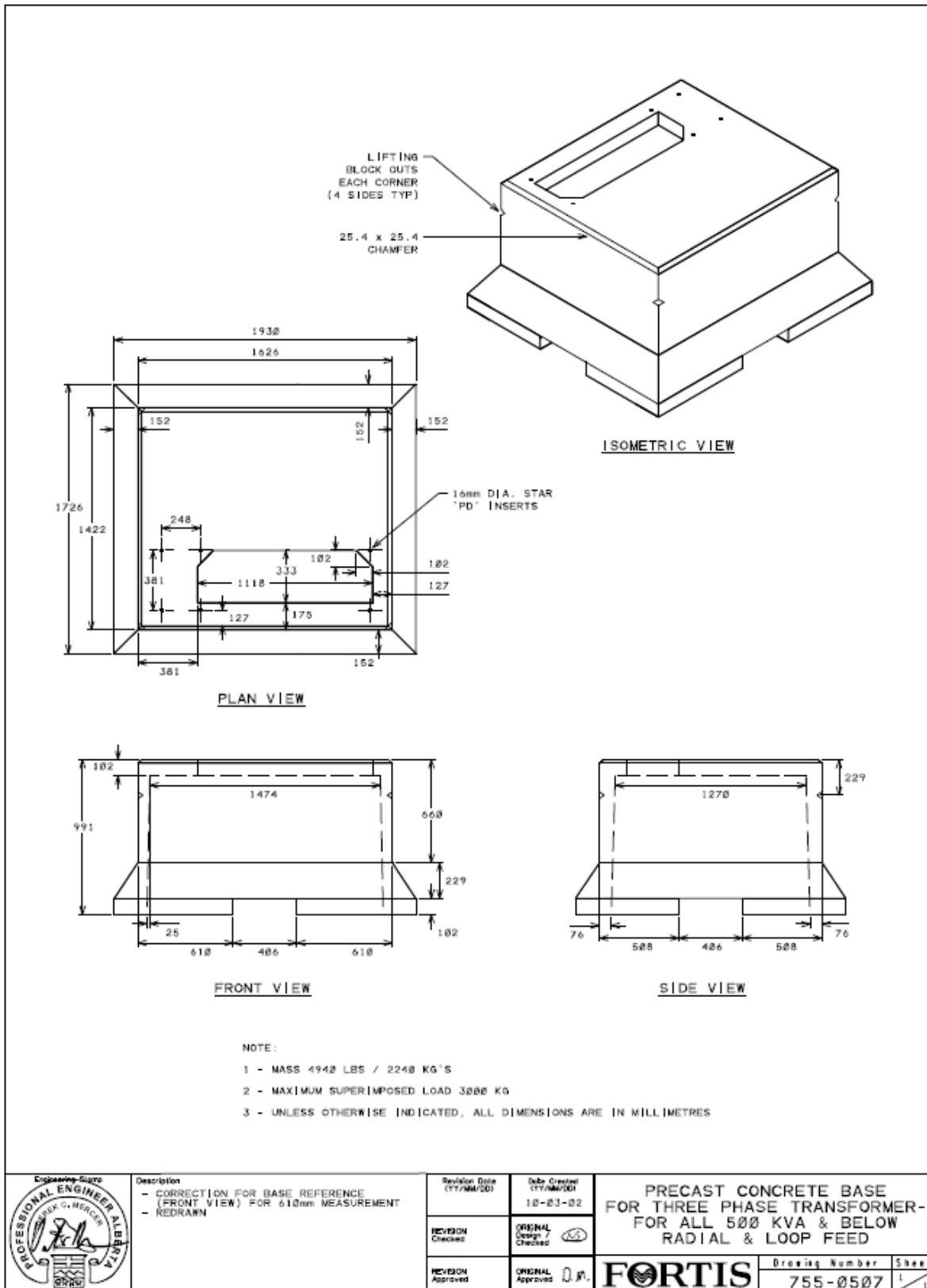

9. Drawing 755-0512, Pre-Cast Concrete Base for 3-Phase Transformer, 750 to 3000 kVA

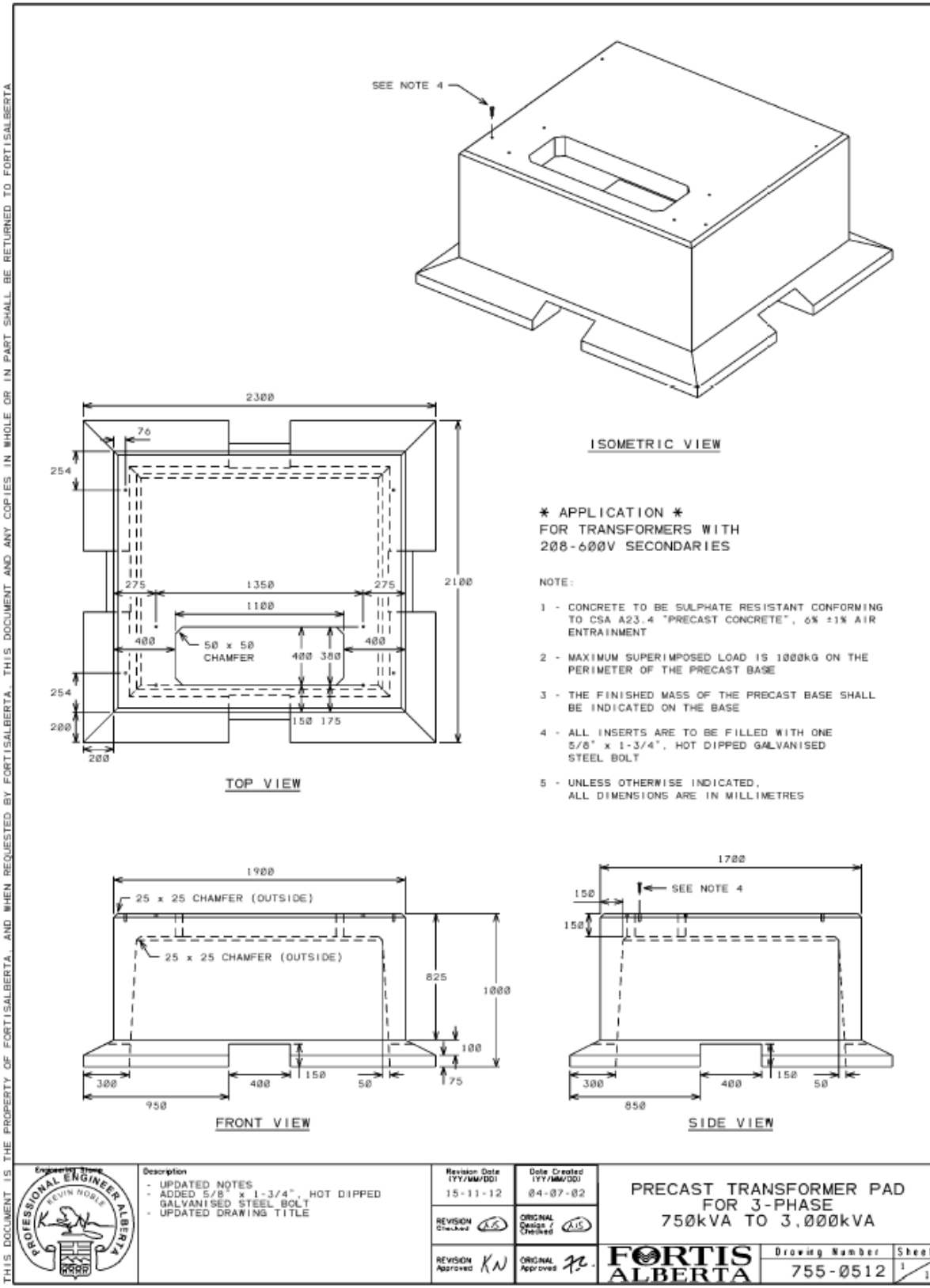

10. Drawing 755-0516, Pre-Cast Concrete Base for 3-Ph Transformer, 1000 to 20000 kVA

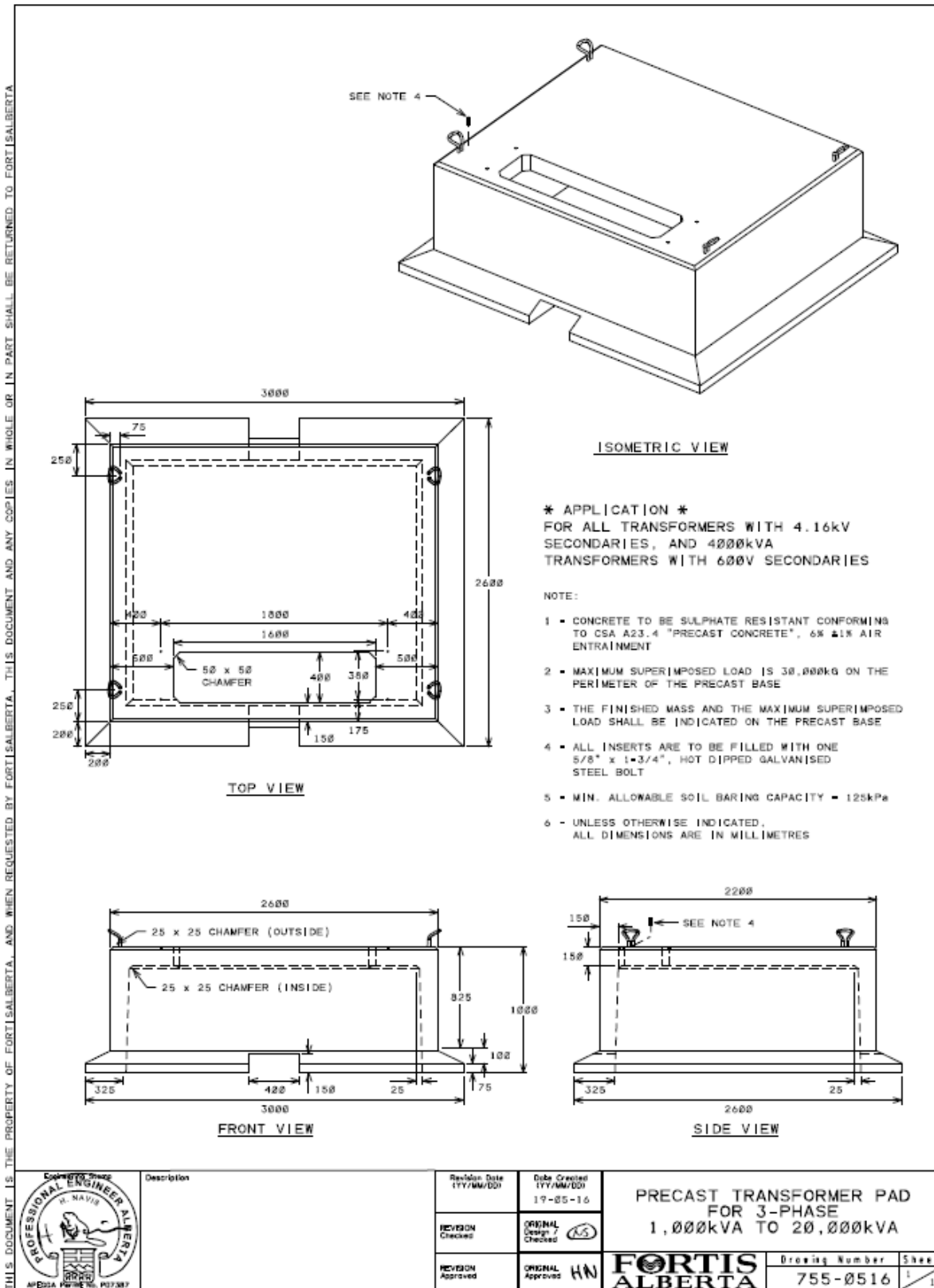

11. Drawing 755-0557, Pre-Cast Concrete Base for 3-Ph Switching Cubicle & 4-Way MVI

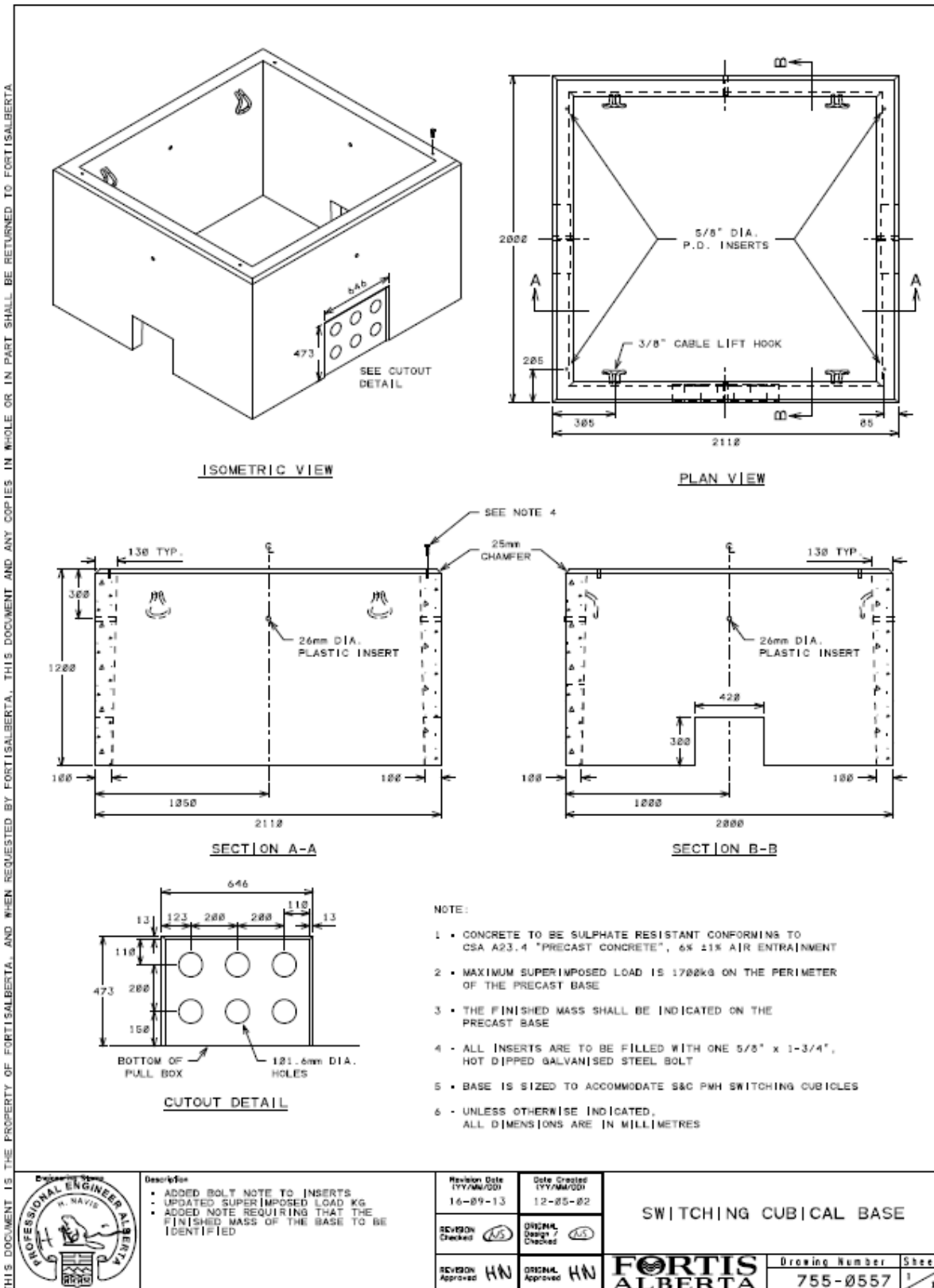

12. Drawing 755-0570, Pre-Cast Concrete Base for 3-Phase, 2-Way MVI

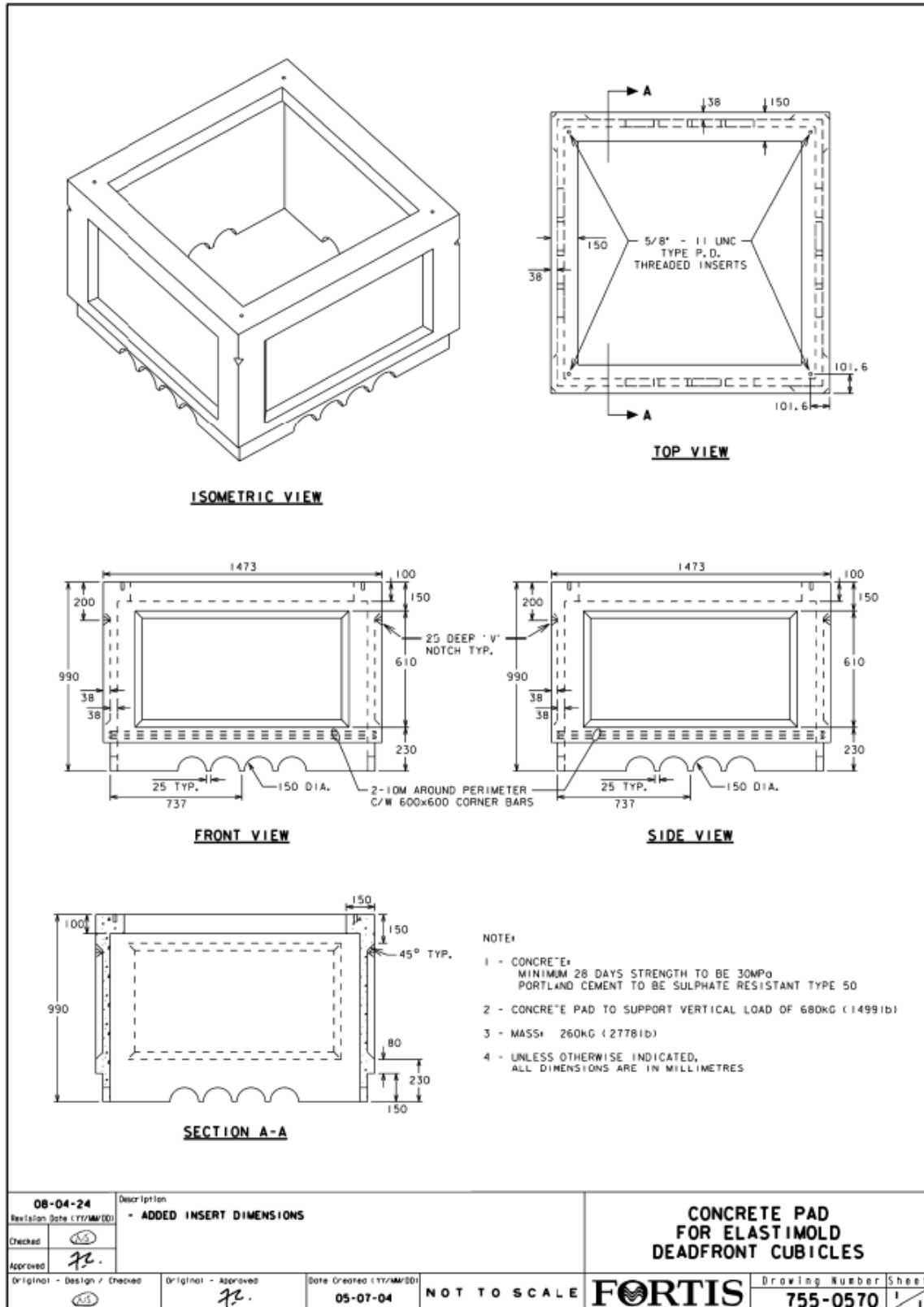

13. Customer Installed Pre-cast Base, Grounding, and Ducting (CIPGD) Process

**FORTIS ALBERTA** **Customer Installed Pre-cast Base, Grounding and Ducting Process – Flowchart**

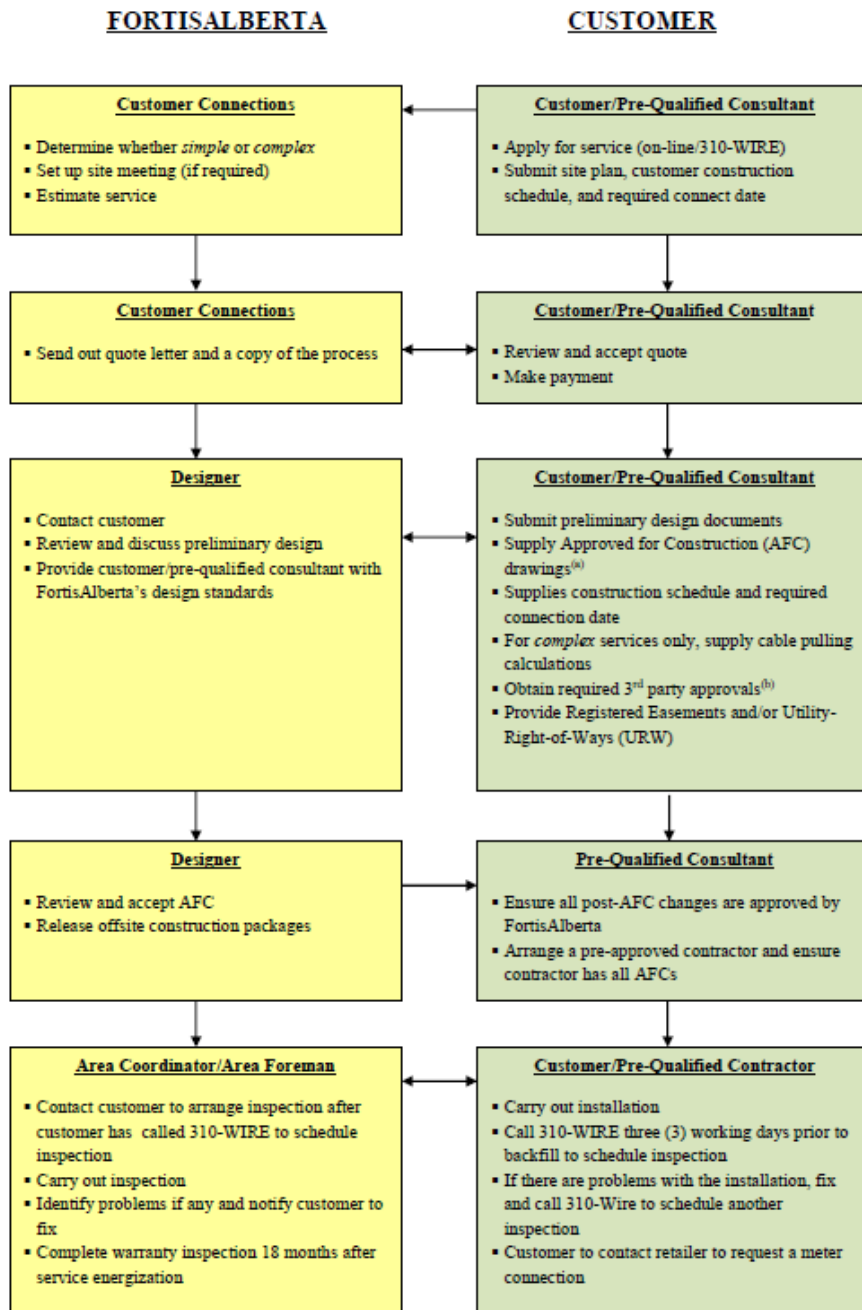

Notes:

- a. In the case of *complex* services, the drawings must be stamped and approved by the pre-approved design consultant's engineer. For *simple* services the drawings do not require the approval of an engineer.



Flowchart.pdf

14. Ground Grid Test Report



Ground Grid Test  
Report.pdf



**GROUND GRID TEST REPORT**

**Development Area and Phase:** \_\_\_\_\_

**Developer Company Name:** \_\_\_\_\_

**FortisAlberta Reference Number:** \_\_\_\_\_ **Land Location:** \_\_\_\_\_

**Tested By:** \_\_\_\_\_ **Date:** \_\_\_\_\_

**Type of Test Used:** \_\_\_\_\_

Equipment Identifier (Switch #)	Location (Street address, or lot & block #)	Ground Resistance Measured	Date Tested	Tester's Signature



15. Example and Template of AFC for Simple Services



Simple AFC.pdf

**AFC Drawing Example**

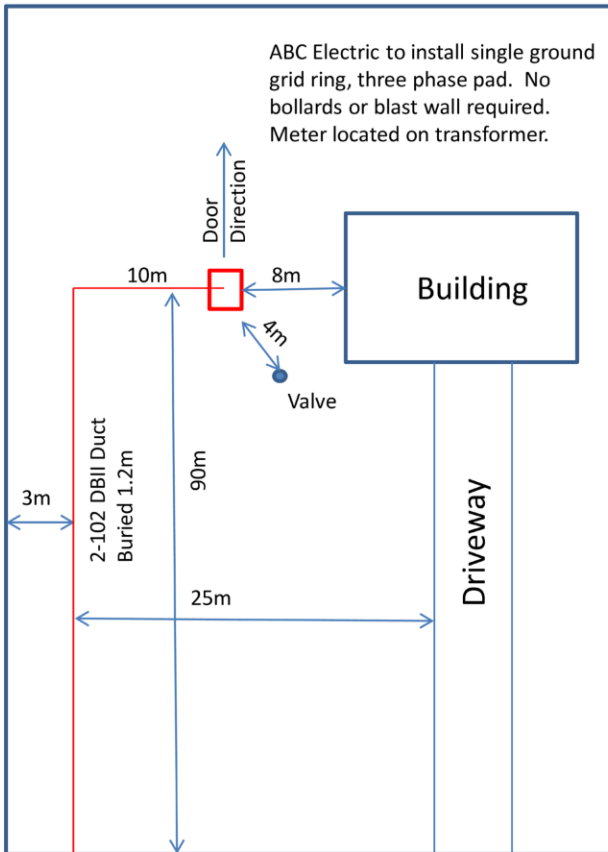

**CHECKLIST:**

- Ground grid: (Single ring ground grid / Three ring ground grid)
- Guard posts (bollard) required: (Yes / No)
  - If yes, indicate number of guard post: \_\_\_\_\_
- Blast wall required (Yes / No)
- Marked as "Approved for Construction (AFC)": (Yes / No)
- Trench and equipment locations are to final grade (+/- 150mm): (Yes / No)
- Drawing shows the following:
  - Show distances from transformer and trench alignment to buildings, property lines, and above and below ground utilities such as:
    - Hydrants / Valves
    - Shallow utilities (gas, telephone, cable)
    - Deep utilities (sewer, water, etc.)
    - Driving surfaces
  - 4.0m clear space to transformer doors (opening)
  - Show metering location.
- Ducting system:
  - Indicate quantity, size, type, and set depth of duct (i.e., 2-102mm DB2 set depth of 1.2m)
  - Specify length of duct (per segment) and bend deflections (i.e., 45°, 90°)
  - Bends and elbow ducts must be rigid, thick-walled PVC (Schedule 40)
  - Additional 10-foot horizontal section of rigid, thick-walled PVC must be attached to the bend.
  - Bends and elbows must be encased with a minimum of 76mm concrete where cable pull tensions are greater than 750 lbs.



AFC Drawing.pdf

## AFC DRAWING



### **CHECKLIST:**

- Ground grid: (Single ring ground grid / Three ring ground grid)
- Guard posts (bollard) required: (Yes / No)
  - If yes, indicate number of guard post: \_\_\_\_\_
- Blast wall required (Yes / No)
- Marked as "Approved for Construction (AFC)": (Yes / No)
- Trench and equipment locations are to final grade (+/- 150mm): (Yes / No)
- Drawing shows the following:
  - Show distances from transformer and trench alignment to buildings, property lines, and above and below ground utilities such as:
    - Hydrants / Valves
    - Shallow utilities (gas, telephone, cable)
    - Deep utilities (sewer, water, etc.)
    - Driving surfaces
  - 4.0m clear space to transformer doors (opening)
  - Show metering location.
- Ducting system:
  - Indicate quantity, size, type, and set depth of duct (i.e., 2-102mm DB2 set depth of 1.2m)
  - Specify length of duct (per segment) and bend deflections (i.e., 45°, 90°)
  - Bends and elbow ducts must be rigid, thick-walled PVC (Schedule 40)
  - Additional 10-foot horizontal section of rigid, thick-walled PVC must be attached to the bend.
  - Bends and elbows must be encased with a minimum of 76mm concrete where cable pull tensions are greater than 750 lbs.

16. Example of AFC for Complex Services



Complex AFC.pdf

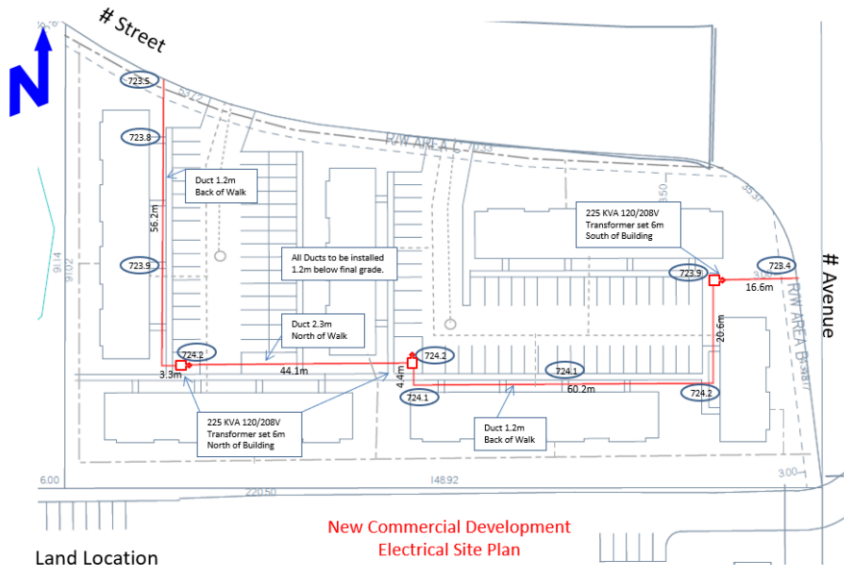

Land Location  
Address  
Developers Name;  
Electrical Engineer Stamp & Signature

New Commercial Development  
Electrical Site Plan  
Title Block

**CHECKLIST:**

- o Ground grid: (Single ring ground grid / Three ring ground grid)
- o Guard posts (bollard) required: (Yes / No)  
If yes, indicate number of guard post: \_\_\_\_\_
- o Blast wall required (Yes / No)
- o Marked as "Approved for Construction (AFC)": (Yes / No)
- o Trench and equipment locations are to final grade (+/- 150mm): (Yes / No)
- o Drawing shows the following:
  - Show distances from transformer and trench alignment to buildings, property lines, right of ways, and above and below ground utilities such as
    - Hydrants / Valves
    - Shallow utilities (gas, telephone, cable)
    - Deep utilities (sewer, water, etc.)
    - Driving surfaces
  - 4.0m clear space to transformer doors (opening)
  - Show metering location.
- o Ducting system:
  - Indicate quantity, size, type, and set depth of duct (i.e., 2-102mm DB2 set depth of 1.2m)
  - Specify length of duct (per segment) and bend deflections (i.e., 45°, 90°)
  - Bends and elbow ducts must be rigid, thick-walled PVC (Schedule 40)
  - Additional 10-foot horizontal section of rigid, thick-walled PVC must be attached to the bend.
  - Bends and elbows must be encased with a minimum of 76mm concrete where cable pull tensions are greater than 750 lbs.

18. Application to Install Underground Electrical Distribution Systems Without Curbs and Gutters



Application Curbs  
And Gutters.docx



**APPLICATION TO INSTALL UNDERGROUND  
ELECTRICAL DISTRIBUTION FACILITIES  
WITHOUT CURBS AND GUTTERS**

**Development Area and Phase:**

**Developer:**

**FortisAlberta Reference Number:** \_\_\_\_\_

**Date:**

In pursuant to the Underground Electrical Distribution Services Agreement and in accordance with the Underground Electrical Distribution Systems (UEDS) Manuals, Part 1 to 5, (the “Developer”) and \_\_\_\_\_ of the firm \_\_\_\_\_ (the “Consulting Engineer”) requests FortisAlberta’s Acceptance of the proposed development or part of the development area being applied for (the “**Work area without curbs and gutters**”), to proceed with the installation of underground distribution facilities without curbs and gutters due to the following reasons:

**REASONS:**

---

---

---

The Developer and the Consulting Engineer agrees and commits:

*(The following shall be submitted and/or completed along with this request and prior to start of construction on the “Work area without curbs and gutters”):*

1. To provide a Facility Map of the location of the “Work area without curbs and gutters.”
2. To obtain a written approval from the governing body (i.e., Municipality), as applicable, in respect to the development area, to proceed with the installation of underground electric distribution facilities without curbs and gutters.
3. To provide a plan showing the proposed final ground line elevation along the trench alignment and at all equipment locations.
4. All trench and grade stakes shall be installed every 10 meters along the proposed alignment and at equipment locations. These stakes need to be in place and preserved for AC inspection.

*(The following shall be performed during the construction of the Work within the “Work area without curbs and gutters”):*

5. To arrange with the FortisAlberta Crew Lead/Unit Price Area Coordinator to perform inspections prior to back fill of the trench. (FortisAlberta Crew Lead/Unit Price Area Coordinator requires five (5) day notice prior to the actual performance of the Work).
6. Record/capture the elevation at the top of the duct/cable and at the top of equipment pads after installation. This information should be contained in the provision of a **grading as-built plan**.

*(The following shall be completed and submitted upon completion of the Work within the “Work area without curbs and gutters” and will form part of the requirements prior to FortisAlberta’s Acceptance and issuance of Functional Completion Certificate):*

7. To provide a grading as-built plan showing the actual ground elevation after backfilling and the recorded elevations at the top of the installed duct/cable along the trench alignment and at the top of all equipment pad locations.

**Note:** The actual ground elevation after backfilling shall be within +/- 150mm (6 inches) of the proposed final grade elevation. Upon submission of a grading as-built plan, no other excavation work (i.e., cutting, fill) be made along the installed facilities without a written consent of the FortisAlberta Crew Lead/Unit Price Area Coordinator.

FortisAlberta reserves the right to have the Developer hydrovac at locations as deemed appropriate and witnessed by the FortisAlberta Crew Lead/Unit Price Area Coordinator to confirm that the actual depths of the ducts/cables are within 1.0m to 1.2m for standard trench and 1.2m to 1.5m for road crossings, from final ground line elevation.

All deficiencies and non-compliances of the required work are the responsibility of the Developer.

**Developer Representative:**

**Consulting Engineer:**

Signature: \_\_\_\_\_

Signature: \_\_\_\_\_

Name and Title: \_\_\_\_\_

Name and Title: \_\_\_\_\_

**Annex C Service and Metering Guide, Conduit Systems (Normative)****C1. Trenching and Backhoe**

- All proposed cable routing and duct work for primary cable installation on behalf of FortisAlberta is subject to written approval by FortisAlberta before construction approval.
- As a customer, you cannot do any excavation work in the Utility Right of Way but must complete all trenching on your property.
- Underground service lines must be kept a minimum of 1.0 m from the edge of the property line.
- The Customer's contractor must not trench within 1.0 m of any FortisAlberta wood pole, anchor, transformer, switching cubical ground grid (2.0 m from the edge of the concrete base, and from 300 mm of the bollard when installed), power pedestal, or energized cable without prior consultation with FortisAlberta. The facilities must be located first using hydro excavating or hand digging before determining where the mechanical excavation limits end.
- Ensure that the top of the duct is a minimum of 1,000 mm to a maximum of 1,200 mm below finished grade for normal trenching and 1,500 mm for road crossings. Service cable shall be set on undisturbed soil that is free from rocks, debris, and sudden grade changes. If large lumps of clay and soil have hardened due to dry or freezing, and when a backhoe has been used for electrical service installation, a 100 mm layer of sand must be placed below the cable. For all service installations, a 100 mm layer of sand must be placed above the cable. Resulting in a 200 mm sand layer.
- A marker tape must be installed above the sand bed
- Install a marker ball at splices and mark the end of the conduit on property line.
- The Customer must backfill all trenches with material that is free of stones and items with sharp edges.
- Backfill must be placed in uniform lifts not exceeding 300 mm and compacted to a minimum of 95% at a 5% moisture content of Standard Proctor Density (SPD) for silty and clay soils and a minimum of 70% relative density for cohesionless, free draining materials (such as sands and gravels) REF; ASTM D1556 [B4]
- Backfill material over cable can be the material trenched with a mechanical trencher if the inspector deems it suitable. Soil with high thermal resistivity that contains large amounts of organic peat, black loam, sod, hardened clay, stones, straw, snow, or frozen material will not be acceptable. All backfill material is subject to the inspector's approval. Sand or clean backfill material must be substituted for unusual backfill.
- The trench must take the most direct route to the meter base location.
- Some work may be required over energized primary or secondary cable. This may involve crossing over trenching the cables. Mechanical excavation is allowed up to 3.0 m from the energized facilities i.e., switching cubical or riser pole (FortisAlberta will trench the rest of the way). The facilities must first be located using hydrovac or hand digging before determining where the mechanical excavation limits end.

- FortisAlberta will allow a contractor to over trench up to 5.0 m of energized facilities by hand or hydrovac. Follow Alberta One-Call procedures and contact 310 Wire (310-9473) before starting work.
- Exposed energized cables cannot be left unattended. If the excavation is narrow or small, the primary cable must be covered with soil bags or some other suitable temporary method. Contact us for more details.
- Under no circumstances must energized primary cables be moved or handled in any way.
- When a trench has been backhoed, cables must be covered with 300 mm of sand. Backhoed material cannot be placed over cable.

## **C2. Service Ducts**

- FortisAlberta reserves the right of final approval for the location of facilities before granting construction approval.
- It is recommended that permanent commercial service cables be in duct.
- For residential installations, FortisAlberta highly recommends installing any cable that will end up under driveways or laneways, in duct.
- Duct must be installed where primary cable is deemed inaccessible by FortisAlberta. All ducts must be equipped with bell collars to avoid damaging the cable.
- The installation of primary service cable under buildings is not permitted.
- The Customer will provide all conduits (rigid PVC, DB2, HDPE or various trenchless race way duct approved by FortisAlberta), pull boxes, and manholes required for installing the electrical services on the Customer's property.
- The Customer cannot install ducts into an energized manhole or handhole of a vault.
- Conduit sizes requirements for primary (high voltage) cables depend on cable size and number of cables to be installed in the duct. FortisAlberta offers two sizes 4" and 6" for duct systems.
- When FortisAlberta conduits have been stubbed to the property line, Customers must first confirm that the conduit exposed is the correct one, and then connect their service entrance conduit to FortisAlberta's conduit if provided. Contact 310 Wire (310-9473) to arrange for conduit verification.
- If pulling lengths exceed the maximum pulling tension of the cable, a pull box must be installed.

## **C3. Duct Bends**

- All bends and elbows must be made of rigid, thick-walled PVC (schedule 40).
- All bends and elbows that have a pull tension more than 750 lbs shall be concrete encased with a minimum of 76 mm throughout the bending radius of the duct. Ducts encased in concrete shall be separated from each other by at least 25 mm of concrete. The concrete mixture shall have a compressive strength of 17.2 MPA (2500 psi) minimum.

**NOTE: The intent of encasing ducts in concrete is to avoid damaging the cable and to avoid pulling the duct out of the ground during cable installation.**



Figure C3.1 Ducting damaged while pulling cable.

- An additional 10-foot horizontal section of rigid, thick-walled PVC must be attached to the bend.
- The primary duct must be aligned directly underneath the primary transformer bushings and centered within the base opening. The conduit bends must exit the earth at 90 degrees, cut-off at 100 mm above the bottom of the base, and a bell end or collar installed at the end of the duct to avoid damage to the cable.
- All spare bends are to be capped (taped or covered by some other suitable method) to prevent material falling into them.
- Primary ducts entering switching cubicles must be identified (i.e., identify the piece of equipment the pipe services).
- Precast concrete pads must be removed before inserting additional ducts into existing pads.



**Annex D Service and Metering Guide, Section 15.4 (Normative)**

15.4. Conduit Materials

Description	Approved Suppliers	FortisAlberta Drawing No. or Cat. No.
PIPE, nominal size 2 inches, rigid PVC, belled end, per CSA Standard C22.2 No. 211.2 latest revision.	Any electrical distributor	
PIPE, nominal size 4 inches, rigid PVC, belled end, per CSA Standard C22.2 No. 211.2 latest revision.	Any electrical distributor	
PIPE, nominal size 4 inches, PVC, type DB2, belled end, per CSA C22.2 No. 211.2 latest revision. (Note: Service and metering guide to be updated)	Any electrical distributor	
<p><b><u>For use on road crossings:</u></b></p> <p>PIPE, High density polyethylene 4-inch IPS SDR 11.0 Polytubes HDPE pipe PE-4710 12.2m pipe, M.O.P. =202 PSI for conduit. The pipe coloring should be black. (<b>FortisAlberta item # 632-3010</b>) <b>NOTE:</b> FortisAlberta is moving away of use of this material. Last use date is February 1, 2024. Use item # 632-3008 instead.</p>	Polytubes	PE-4710
PIPE, High density polyethylene, 4-inch IPS, SDR 11, 4.5-inch average O.D., 3.633-inch average I.D., 0.409-inch minimum wall thickness, bend radius 50 inch, UV stable red coloring or red with black stripping are acceptable, per CSA C22.2 no. 327. ( <b>FortisAlberta Item # 632-3008</b> )	IPEX  Dura-Line  United Poly Systems	D40005ARDNNNNSTS
PIPE, trenchless raceway, nominal size 4", schedule 40, PVC, 20-foot length, belled end, c/w locking strap for a glue less joint, 8,700 lbs rated pulling force, 1075 lbs crush (@30% deflection), 65 ft minimum bending radius, suitable for directional drilling applications ( <b>FortisAlberta item # 632-3015</b> )	Carlton	BG440SP-020

Description	Approved Suppliers	FortisAlberta Drawing No. or Cat. No.
BRACKET, Standoff, multipurpose, for mounting multiple conduits on a pole, aluminum. (FortisAlberta item # 589-0450)	Aluma-Form	6B-CSO-P13/16
BRACKET, 4 way "T-slot", 12-inch-long (FortisAlberta item # 589-0455)	Aluma-Form	4WT-12
	Hubbell	C4WT-12
	Maclean	M4WT-12
Strap kit, 2 inch (FortisAlberta item # 631-1108)	Aluma-Form	STK-2
	Hubbell	CSTK2
	Maclean	MSTK-2
Strap kit, 4 inch (FortisAlberta item # 631-1110)	Aluma-Form	STK-4
	Hubbell	CSTK4
	Maclean	MSTK-4

**Annex E    Service and Metering Guide, Section 15.5 (Normative)**

15.5 Grounding Material

15.5.1 The following material is required to install the ground grid around padmount transformers:

Description	Approved Suppliers	FortisAlberta Drawing No. or Cat. No.
#4 bare copper conductor, stranded (FortisAlberta item # 531-0220)	Any electrical distributor	
#2/0 bare copper conductor, stranded (FortisAlberta item # 531-0202)	Any electrical distributor	
For use on transformer grounding: <ul style="list-style-type: none"> <li>Sectional ground rods, 3/4" x 4', tapered at both ends (FortisAlberta item # 557-1421)</li> <li>Coupling for sectional ground rods (FortisAlberta item # 557-1525)</li> </ul>		SKT 1499
	Erico	61344 613440
	Erico	CC34
Ground rod connector for use with sectional ground rods (FortisAlberta item # 557-1311)		SKT. 1499
	Burndy/Hubbell	GRC3426
Ground connector for padmount transformers (FortisAlberta item # 553-0611)	Burndy/Hubbell	EQC26CG14
	H-J International	AS1358-001
	Penn-Union	HGSE020-SBHL1
Connector, parallel groove, compression type, copper, for #4 copper str. conductor (FortisAlberta item # 553-0152)	Burndy/Hubbell	YC4C4
	Homac	CC44
	IlSCO	ULT-5
	Kearney/Eaton	302-82
Connector, parallel groove, compression type, copper, for #2/0 copper str. conductor (FortisAlberta item # 553-0155)	Burndy/Hubbell	YGHC26C26
	IlSCO	ELT-2
	Thomas and Betts	CTP2020